

1926-27 Coupe and Sedan, 1928-29 Pickup Door, Window, Deck lid, and Interior

Outside Door Handles: 1926-27 Coupe and Sedan 1928-29 Closed Pickup

Handles, Die Cast, Chromed Non Locking, Fit RH or LH A-702350-P	45.00 ea
Rubber Pads B-35630	5.00 pr
Mount screws, stainless 3/4" set of 4 B-46212-MS	2.50 set
Lock Cylinder (originally 26-27 only) B-41650	17.50 ea

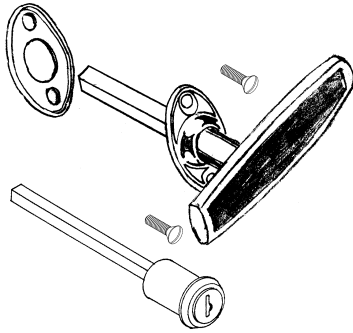

Inside Latch Handle Knob: 1926-27 Closed Car, 1928-29 Pickup

A-35710	Knob, chrome plated	10.00 ea
T-8320-BX	Handle shaft anti-rattler, rubber	7.50 pr



Inside Window handles: 1926-27 Closed Car 1928-29 Pickup

A-702780-A	Window riser handle, chrome plated	12.50 ea
A-46250-P	Handle to shaft pin	0.25 ea
A-48139-A	Escutcheon, standard, chrome plated	5.00 ea
A-48139-B	Escutcheon, deluxe, chrome plated	7.50 ea
B-48284	Escutcheon spring (under upholstery)	0.50 ea

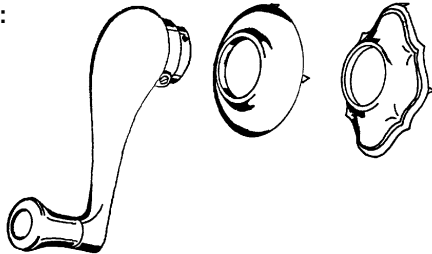

1928-56 Panel Truck Back Door Handles

A-702400-C	Chrome plated	10.00 ea
------------	---------------	----------



Door Garnish Moldings,

1926-27 Coupe & Tudor Sedan, 1928-29 Pickup

Stamped Steel

Door lower, finger pull

A-80033-S		175.00 pr
-----------	--	-----------

Door upper frame

1928-29 Pickup Style		
A-80025	RH	95.00 ea
A-80026	LH	95.00 ea

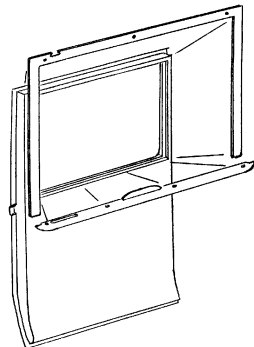

1926-27 Coupe Quarter Window Garnish Moldings

Fiberglass with return flange
against door edge, not a raw edge

CG2627QR	RH	230.00 ea
CG2627QL	LH	230.00 ea



1926-27 Tudor Sedan Quarter Window Garnish Moldings

Upper T-56051-UQ	not.avbl
Lower (1928-31: Trim to fit 1926-27) A-56050-Q	175.00 pr

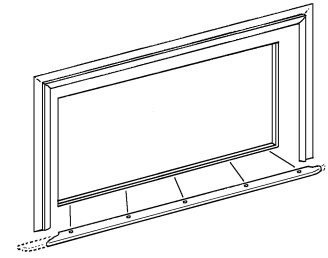

1926-27 Coupe & Tudor Back Window Garnish Molding

Fiberglass with return flange
against door edge, not a raw edge.
RWM2627CS



1928-29 Pickup Back Window Garnish Moldings

A-83820-AR	1928-29 Pickup, stamped steel	32.50 ea
------------	-------------------------------	----------



Typical 1926-27 Coupe, 1928-29 Pickup Window Parts

Felt Kits

Includes window run felt
channels for 2 windows,
both right and left sides. Felt
channels have attaching clips
installed. Window top seals
(sponge style) and adhesive
are included.

A-45983-PU	1926-27 Coupe & Tudor, 1928-29 Pickup cab	120.00 ea
------------	---	-----------

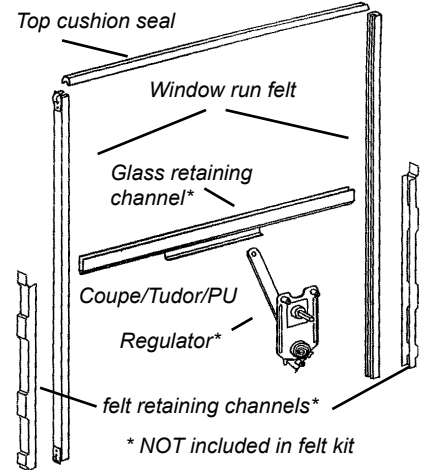

* NOT included in felt kit

Window Glass Top Cushion Only

Sponge style top cushion is included in
window felt kits as needed.

1926-27:

T-8399-T	Cushion, fits in retainer	7.50 ea
T-8399-TR	Retainer, steel	35.00 ea

1928-33

A-45983-T	Sponge style, glue in	5.00 ea
-----------	-----------------------	---------

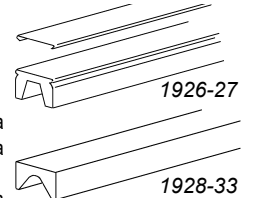

Regulators and Glass Channel: Coupe, Tudor and Pickup

A-48105-A	Regulator: RH Door and Quarter	65.00 ea
A-48106-A	Regulator: LH Door and Quarter	65.00 ea
A-45962-S	Channel: fits RH or LH door	30.00 ea
A-56787	Channel: fits RH or LH quarter (tudor sedan)	30.00 ea

Window Glass to Frame Setting Tape

B-37193-A	all years, 20 ft, 1/32" thick	17.50 ea
B-37193-B	all years, 20 ft, 3/64" thick	17.50 ea
B-37193-C	all years, 20 ft, 1/16" thick	25.00 ea
B-37193-D	all years, 20 ft, 5/64" thick	30.00 ea

* Parts with price listed as "not.avbl" are not known to be available at this time, but are listed for reference.

1926-27 Coupe and Sedan, 1928-29 Pickup Door, Window, Deck lid, and Interior, cont

Fixed Quarter & Back Window Glass Rubber Channels

1926-36 Coupe & Sedan

B-704220 10' 15.00 ea

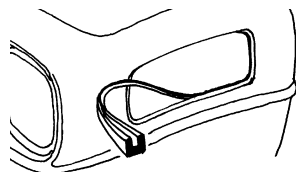

Door Latches, Striker, bumpers

1926-27 Coupe & Sedan

1928-29 Pickup



bumper retainer

dovetail

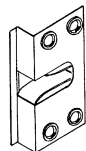
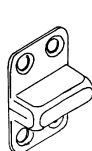

striker

A-80081	Door latch: LH	150.00	ea
A-80082	Door latch: RH	145.00	ea
A-80055-RK	Latch repair: Spring & rivet kit for both sides	30.00	ea
A-80331	Door latch striker	12.50	ea
A-702610-NS	Door rubber bumper kit	10.00	set
A-80332	Door Jamb Bumper Retainer (28-29 PU only)	7.50	ea
A-76819	Male dovetail, chrome plated	5.00	ea
A-80333	Dovetail Socket (28-29 PU only)	12.50	ea

Weather Seals

Windlacing was used to seal the front, top, and back of doors. A rubber seal strip was attached under the upholstery at to bottom of door.

Lower Door Seal

A-701980 Front doors use 1 ea, Rear doors 1/2 each 15.00 ea

Interior Trim Screw Sets

AH-288 1928-29 Closed pickup cab 22.50 set

1926-27 Coupe & Tudor Sedan Sill Plates

T-46480-CS	fits bodies with wood framing around windows	not.avbl
T-46480-DS	fits bodies with steel framing around windows	not.avbl

Trunk Lid Hinges, Latch, and Prop

1926-27 Coupe

Note: 1926-27 trunk lids did not use bumpers.

T-9485-C	Hinges, original pin style	115.00	pr
T-9487-A	Prop,	70.00	ea
T-9486-X	Prop catch on body,	20.00	ea
T-9488	Alignment	27.50	pr
T-9545-L	Latch, original style	25.00	ea
T-9484-B	Latch Key, Chrome	10.00	ea

Use to unlatch and lift lid

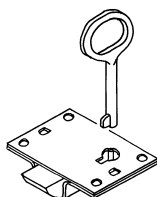

Door Hinges: 1926-27 Coupe & Sedan

1928-29 Pickup and Panel Door

Cast steel. Drilled for hinge pin only. Body mounting holes are not drilled.

Cut to length.

Ford used two styles of hinges, complete hinges will replace all hinges, individual straps will not replace spline type hinge.

Hinges:

A-46300-TC	Cowl strap only	60.00	ea
A-46300-TD	Door strap only	60.00	ea
A-46300-TS	Set of 6 hinges with pins	700.00	ea

Pins and Screws:

A-46335	Hinge Pins, plain	1.00	ea
A-46335-SS	Hinge Pins, Stainless	5.00	ea

Hinge screws are 1/4-28 with countersunk lockwashers.

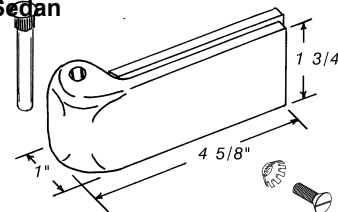

Door Check Straps

Rubber Loop Style

Loop Check Straps

A-162592-6	6"	7.50	ea
A-162592-7	7"	7.50	ea
A-162592-8	8"	7.50	ea

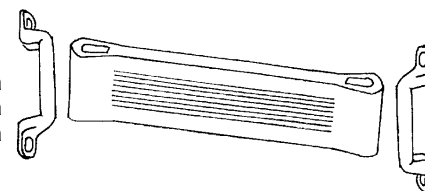

Loop check strap bracket:

A-162592-E 1.00 ea

* Parts with price listed as "not.avbl" are not known to be available at this time, but are listed for reference.