

1933-34 Coupes, Sedans, Victoria, Cabriolet Door, Window, Deck Lid, and Interior

Door Handle:

1933-34 Coupes, Sedans, & Cabriolet

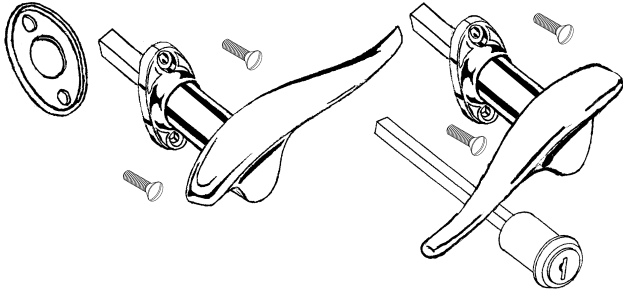

40-702350	RH Front (LR) Handle, nonlock, chrome	32.50	ea
40-702351	LH Front (RR) Handle, nonlock, chrome	32.50	ea
40-702350/1-L	RH & LH Handles, locking, diecast chrome	100.00	pr
40-702350/1	RH & LH Handles, nonlock, stainless clad	not.avbl	
B-46212	Rubber pads (with bead)	5.00	pr
B-46212-MS	Mounting screws, stainless 3/4" set of 4	2.50	set
B-41650	Key Cylinder (Briggs & Stratton replacement)	17.50	ea

Deck Lid Handle: 1932-34 Rumble or Trunk Lid Handle

Locking, w/keys,
mount outside lid.
Die Cast, chrome

plated. Will fit 1928-37.

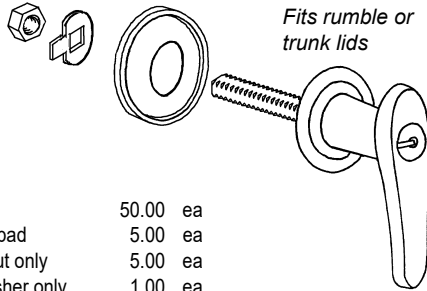

40-702352	Handle	50.00	ea
B-41648	Rubber pad	5.00	ea
A-41606-S	Acorn nut only	5.00	ea
A-41606-LW	Lockwasher only	1.00	ea

1933-34 Closed Passenger

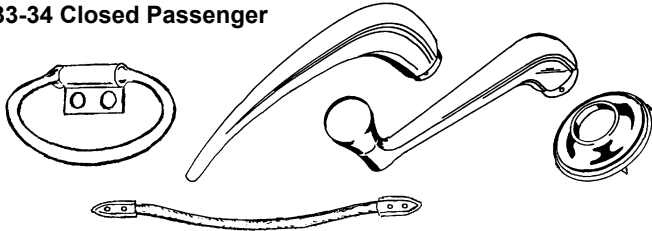

40-702400-ES	Inside door handle, chrome	12.50	ea
40-702780-ES	Window riser handle, chrome	12.50	ea
40-722470	Back & quarter window "T" handle, chrome	20.00	ea
40-725900	Remote rumble release handle, chrome	17.50	ea
A-46250-P	Handle to shaft pin	0.25	ea
40-48139-C	Escutcheon, stainless	7.50	ea
B-48284	Escutcheon spring (under upholstery)	0.50	ea

Door Lock Inside Turn Knob, Chrome Plated

A-61148-CR	1933-34 Passenger LF and fordor rear	12.50	ea
------------	--------------------------------------	-------	----

Door Close Assist Handles

40-702420-A	1933 ring style, stainless	50.00	pr
40-702420-B	1934 cord style, fabric w/chrome ends	50.00	pr

Arm Rest Formers

A-56665-PR	Front door, 1932-48 Passenger	95.00	pr
A-56666-PR	Rear seat, 1930-34 Sedan	70.00	pr

1933-34 Garnish Moldings

Fiberglass, with return flange
on glass side

Door: 1933 5 Window Coupe

CG333W5DR	RH	285.00	ea
CG333W5DL	LH	285.00	ea

Quarter: 1933-34 5 Window Coupe

CG3334W5QR	RH	230.00	ea
CG3334W5QL	LH	230.00	ea

Back Window: 1933-34 Coupe

RWM3334C	230.00	ea
----------	--------	----

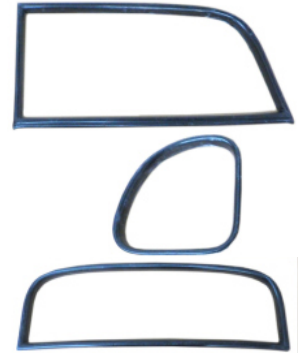

Cabriolet Window Special Parts

B-782144	Glass to body & garnish bumper (5")	7.50	ea
----------	-------------------------------------	------	----

Typical 1933 Coupe & Sedan Window Parts

Top cushion seal

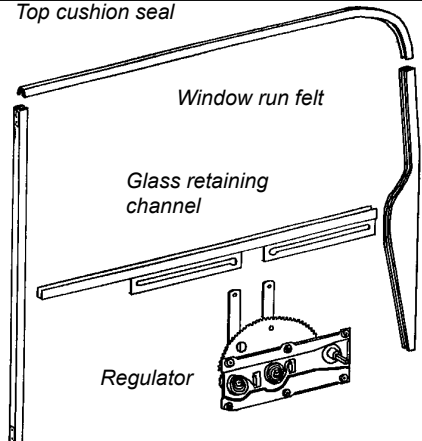

Window Felt Kits

Includes window run
felt channels for both
right and left sides with
attaching clips installed.
Window top seals and
adhesive included.
Regulator and glass
retaining channels not
included.

18-45983-3W	3-Window coupe doors	95.00	ea
18-45983-2D	5 Window, Tudor, Victoria, Fordor front doors	95.00	ea
B-56786	Tudor sedan quarter windows	115.00	ea
18-56791	Fordor rear doors & quarters	120.00	ea
A-46108	Coupe rolldown back window	55.00	ea
A-45983-T	Top cushion only, included in kits	5.00	ea

1933 Window Regulators

18-702700	RF door: Coupe & Sedan, RH Quarter: Tudor	175.00	ea
18-702701	LF door: Coupe & Sedan, LH Quarter: Tudor	175.00	ea

1933 Window Glass Retaining Channels

May need to be trimmed to fit

	RH		LH	
Door, 3 Window	18-45962	55.00	ea	18-45963
Door, 5 W & 4D	B-55962	55.00	ea	B-55963
Door, 2D & Vicky	B-55962	55.00	ea	B-55963
Rear Door, 4D	46-45963	40.00	ea	46-45962
Quarter, 2D & Vky	40-56787-A	55.00	ea	40-56787-A
Quarter, 4D	46-45962	40.00	ea	46-45963
Back Window, Cp	B-47106	40.00	ea	

* Parts with price listed as "not.avbl" are not known to be available at this time, but are listed for reference.

1933-34 Coupes, Sedans, Victoria, Cabriolet Door, Window, Deck Lid, and Interior, cont

Typical 1934 Coupe & Sedan Window Parts

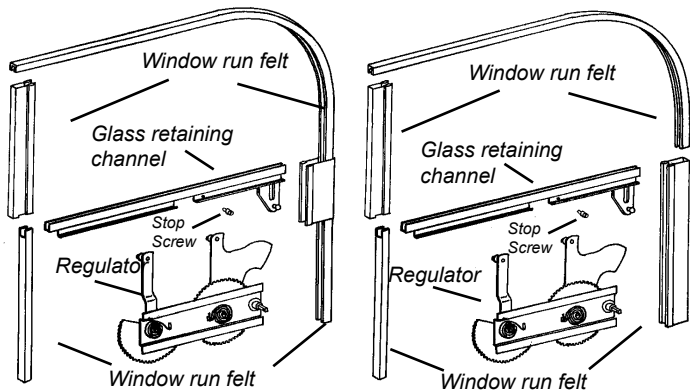

Typical of early 1934 with inside door handle near front of door

Typical of late 1934 with inside door handle near center of door

1934 Roll-Up Window Felt Kits

Important: 1934 used two different types of window felt kits. One type was common to cars with the inside door handle near front of door, the other common to cars with the inside door handle near the center.

Felt kits include all metal and felt lined window run channels (w/mounting clips installed) for 2 windows (both sides of car). Window bumpers (both door and garnish) and installation screws included. Regulator and glass retaining channels not included.

Handle location		To front	Near center
3 Window Coupe	40-45983-3W	140.00 ea	40-45983-3W 140.00 ea
5 Window/4 door front	40-45983-5WF	140.00 ea	40-45983-5WC 140.00 ea
Tudor/Victoria	40-45983-2DF	140.00 ea	40-45983-2DC 140.00 ea
Tudor quarter	40-56786	175.00 ea	40-56786 175.00 ea
Ford rear doors	40-56791-F	140.00 ea	40-56791-C 140.00 ea
Coupe back window	A-46108	55.00 ea	A-46108 55.00 ea

1934 Window Regulators

40-702700	RH Door: Coupe & Sedan, Quarter: Tudor/Vic	155.00 ea
40-702701	LH Door: Coupe & Sedan, Quarter: Tudor/Vic	155.00 ea

1933-34 Front Door Window Glass Retaining Channels

Note: trim to fit for 5 Window and Fordor

40-702170	Door, RH: Coupes, Sedans (front door)	60.00 ea
40-702171	Door, LH: Coupes, Sedans (front door)	60.00 ea
46-45963	Rear door, RH: Fordor	40.00 ea
46-45962	Rear door, LH: Fordor	40.00 ea
40-702170	Quarter: RH: Tudor/Victoria	60.00 ea
40-702171	Quarter: LH: Tudor/Victoria	60.00 ea
B-47106	Back Window: Coupe (roll down)	40.00 ea

Window Glass to Body Seal

Sets glass into channel. When window is rolled up it is sealed to door or body. 6' length.

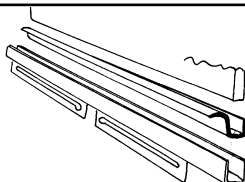

B-45968 10.00 ea

Fixed Quarter & Back Window Glass Rubber Channels

Quarter & Back Window Seal
B-704220 10 ft 15.00 ea

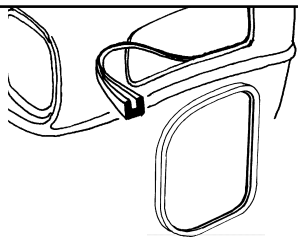

5-Window Quarter Window Seal
Ends seamed as original.
40-704220-S 20.00 pr

Door Hinges:

1933-34 3 Window

Investment cast steel.
Drilled for hinge pin only.
Mounting holes not drilled.
Trim center and lower hinges to fit.

Hinge Straps:

Upper RH (Body) Hinge Strap:	40-723200-C	100.00 ea
Upper RH (Door) Hinge Strap:	40-723200-D	100.00 ea
Upper LH (Body) Hinge Strap:	40-723201-C	100.00 ea
Upper LH (Body) Hinge Strap:	40-723201-D	100.00 ea
Center Hinge (Body) Straps:	B-523202-C	65.00 ea
Center Hinge (Door) Straps:	B-523202-D	65.00 ea
Lower Hinge (Body) Straps:	B-523204-C	80.00 ea
Lower Hinge (Door) Straps:	B-523204-D	80.00 ea

Hinge Pins

	Plain	Stainless
hinge pins	B-46335 2.50 ea	B-46335-SS 5.00 ea
Hinge to body	Screws, 1" long	Washer
Plain steel	B-35600-M100 2.00 ea	B-35600-WW 1.00 ea

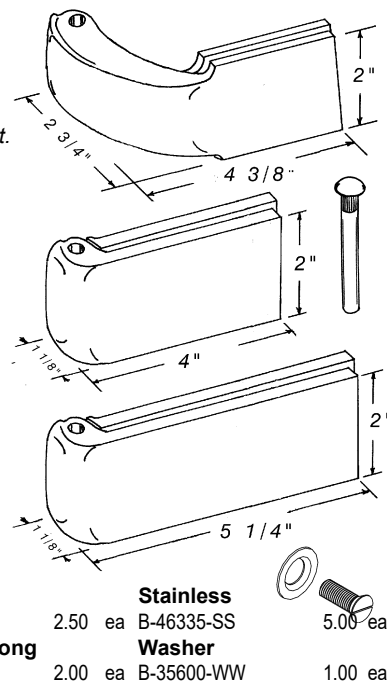

Door Hinges: 1933-34

5 Window Coupe & Tudor

Investment cast steel
Hinge pin holes are drilled.
Mount holes are not drilled.
Straps may have to be cut to length.

Hinge Straps:

Upper & Middle (Body) Hinge Strap:	B-523202-C	65.00 ea
Upper & Middle (Door) Hinge Strap:	B-523202-D	65.00 ea
Lower (Body) Hinge Strap:	B-523204-C	80.00 ea
Lower (Door) Hinge Strap:	B-523204-D	80.00 ea

Hinge Pins

B-46335	plain	2.50 ea
B-46335-SS	stainless	5.00 ea

Hinge to body Screws

B-35600-M100	1" screw	2.00 ea
B-35600-WW	washer	1.00 ea

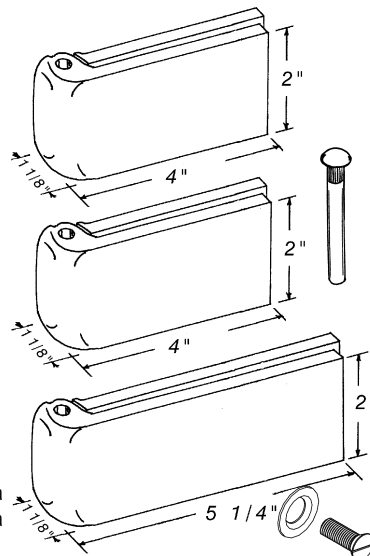

Door Hinges: 1933-34 Cabriolet

Hinge Straps:

Body Hinge Strap:	B-523204-PUC	80.00 ea
Door Hinge Strap:	B-523204-D	80.00 ea

Hinge Pins

B-46335	plain	2.50 ea
B-46335-SS	stainless	5.00 ea

Hinge to body Screws

B-35600-M100	1" screw	2.00 ea
B-35600-WW	washer	1.00 ea

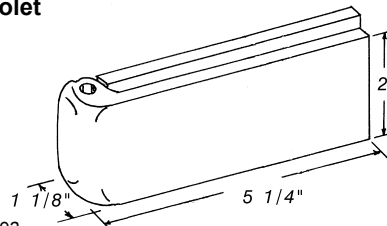

* Parts with price listed as "not.avbl" are not known to be available at this time, but are listed for reference.

1933-34 Coupes, Sedans, Victoria, Cabriolet Door, Window, Deck Lid, and Interior, cont

Rubber Door Check Straps, "T" Style

B-162592-T	Check strap	7.50 ea
B-162592-S	Clamp bracket	5.00 ea



Door Latch: 1933-34 Coupe, Sedan, Convertible

Door Latch:

40-7021812/3-A	1933	not.avbl
40-7021812/3-B	Late 1933-Early 1934	not.avbl
40-7021812/3-C	1934	not.avbl

Door Latch Repair:

40-702267-B	Spiral spring	5.00 ea
B-702268	Inside handle spring	5.00 ea

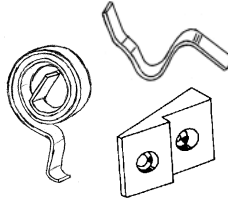

Inside Handle Mount (Mid-Late 1934)

81A-732412/3-NA	Mount w/o link	50.00 pr
-----------------	----------------	----------

Door Latch Striker:

B-46137-A	Striker, plain	15.00 ea
40-702340-SS	Striker, stainless	17.50 ea
48-702336-A	Striker nut plate	17.50 pr

Door Bumpers and Dovetails

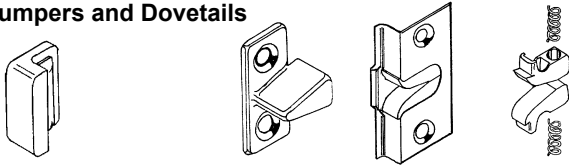

B-46440	Bumper,	1.50 ea
40-702550-D	Dovetail, stainless	15.00 ea
40-702550-S	Dovetail mount screws	2.00 set
40-46412-BS	Dovetail socket: Plain	not.avbl
40-46412-SS	Dovetail socket: Stainless	50.00 pr
B-702574-RK	Dovetail socket repair kit	7.50 ea

Door Weather Seal,

Windlacing was used to seal the front and back of doors. Coupes and sedans use a rubber seal that mounts to the sheetmetal above the door (Most fiberglass bodies cannot use this seal.) A rubber seal strip was attached under the upholstery at bottom of door.

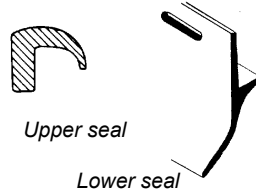

40-7043724-AS	Upper seal kit, for two doors	10.00 set
40-701980	Lower seal, 1 required per door	10.00 ea

1933-34 Door Sill Plates, Stamped Zinc



40-7013250-S	3-Window coupe & Tudor sedan	300.00 pr
40-7613250-S	Cabriolet	300.00 pr
40-7713250-S	5-Window coupe & Fordor front	275.00 pr
40-7313262-S	Fordor sedan rear doors	300.00 pr

Trunk Hinges

1933-34 Roadster & Coupe

Cast 304 Stainless hinges, can be polished or painted.
Made in USA



1933-34
Made in USA

40-713572-TS	400.00 pr
--------------	-----------

Trunk Prop:

40-41530	Prop Arm, 1933-34	90.00 ea
A-41530-MB	Sholder bolt on body	5.00 ea

Rumble Hinges:

1933-34 Coupe, Roadster, Cabriolet

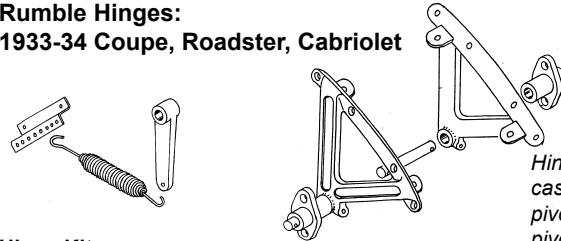

Hinge Kits Include cast hinges, cast pivot brackets, and pivot rod.

Hinge Kit:

40-713570-S	1933-34, cast iron, imported	60.00 set
B-526898-S	Hinge mount reinforcement on body	15.00 pr
B-526812	Counterbalance spring bracket	10.00 pr
B-526813	Counterbalance spring	15.00 pr
B-526814	Counterbalance arm, cast aluminum	40.00 ea

Rumble Lid Latch: Remote Style, Coupe & Cabriolet

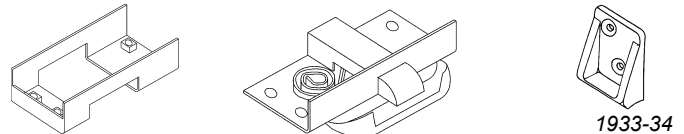

1933-34

B-527102	Latch	27.50 ea
B-527103	Mount bracket, to drip rail	15.00 ea
40-715600	Handle mount & link, Coupe	27.50 ea
40-765780	Striker, 1933-34, cast stainless	60.00 ea

Deck Lid Latch, Outside Handle Style

Trunk Lid Latch (Coupe and Roadster)

Rumble Lid Latch (1933-34 roadster)

A-41604-B	100.00 ea
-----------	-----------

Trunk Lid Striker

40-41615	1933-34	12.50 ea
----------	---------	----------

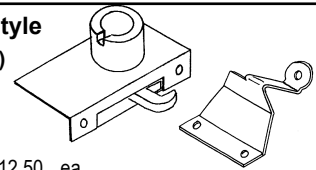

Deck Lid Bumpers and Stops:

Bumpers: Upper on rumble/lower on trunk

B-41518	round,	7.50 pr
---------	--------	---------

Rumble Stop, 1933-34

40-714008-S	Bracket/bumpers	17.50 set
B-41484	Bumpers only	7.50 pr

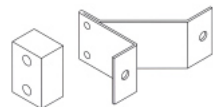

* Parts with price listed as "not.avbl" are not known to be available at this time, but are listed for reference.