

1926-27 Radiator Shell, Hood, Fenders and Running Boards

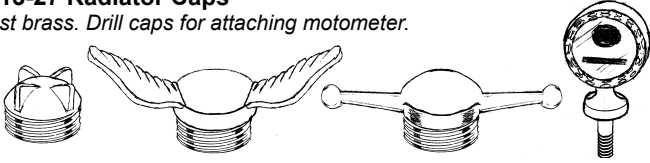

1913-27 Radiator Caps

Cast brass. Drill caps for attaching motometer.



	Polished Brass		Chromed	
Stock cap	T-3926-B	15.00 ea	T-3926-C	17.50 ea
Dogbone cap	T-3926-DB	not.avbl	T-3926-DC	not.avbl
Gullwing cap	T-3926-GB	25.00 ea	T-3926-GC	27.50 ea
Motometer	B-18354-BW	55.00 ea	B-18354-CW	55.00 ea

Radiator Shells & Shields

Radiator Shell:

1917-23 "short" style: (includes shield)

T-8200-A	Plain	180.00 ea
T-8200-AC	Chrome	275.00 ea

1924-25 "tall" style:

T-8200-B	Plain	not.avbl
----------	-------	----------

1926-27 "tall" tapered style:

T-8200-CP	Plain	not.avbl
-----------	-------	----------

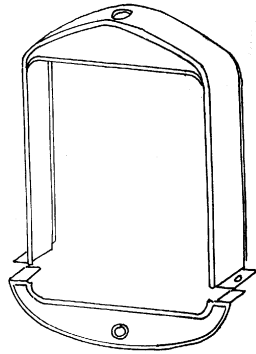

Lower shield & trim:

T-8201-A	1917-25, with crank hole, plain steel	35.00 ea
T-8201-B	1926-27 with crank hole, plain steel	35.00 ea
T-8201-SR	1926-27 no crank hole, plain steel	35.00 ea
T-3977-D	1926-27 lower trim, chrome	20.00 ea

Radiator Shell Mount Bolt Set

A-8201-AM	1923-29	not.avbl
-----------	---------	----------

Chopped 4-1/2" 1932 Grille Shell

Ideal for 1926-27. Features a smooth lacing lip at back of shell.

4-1/2" Chop Grille Shell

GS32PF4	Filled style, fiberglass	400.00 ea
---------	--------------------------	-----------

4-1/2" Chop Grille insert

B-8200-IE	Stainless, No crank hole	not.avbl
-----------	--------------------------	----------

4-1/2" Front Splash Apron

FSA27T2AF	Fits 1926-27 cars using 1928-29 fenders and 4 1/2" chop 1932 grille shell. Fiberglass	230.00 ea
-----------	---	-----------



1926-27 Stock and Street Rod Hoods

Steel hoods by Rootlieb.

4 Piece Hood

1 piece top

or 3 piece with sides

Hood top includes center hinge. (We recommend the V8 hinge on street rods for ease of opening and to help prevent paint chipping). Side panels are complete with hood handles and hinge rods.

Hood top can be used a top panel only. Side panels do not have handles.

Hood hinges and top panel braces not included, sold separately.

Hood Tops

Stock hinge

V8 Style hinge

One Piece

Louvered

	4 piece		3 piece (*no hinge)	
Plain (stock hinge*)	T-16710-E	205.00 ea	T-16710-E3	230.00 ea
Plain (V8 hinge*)	T-16710-E2	215.00 ea		
Louvered (V8 hinge*)	T-16710-E2L	270.00 ea	T-16710-E3L	350.00 ea

Hood Sides

Stock

Hot Rod

3 - Door

Plain

Single Scoop

Double Scoop

	4 Piece		3 Piece	
Sides, stock	T-16712-E	205.00 pr	T-16713-E	170.00 pr
Sides, hot rod	T-16712-EH	205.00 pr	T-16713-EH	170.00 pr
Sides, plain	T-16712-EP	205.00 pr	T-16713-EP	170.00 pr
Sides, single scoop	T-16712-ES1	375.00 pr	T-16713-ES1	500.00 pr
Sides, double scoop	T-16712-ES2	525.00 pr	T-16713-ES2	825.00 pr
Sides, 3-door	T-16712-ED	625.00 pr		

Hinge and Braces for 3-Piece Hoods

Top Panel Braces

3/8" round steel braces provide extra support. This minimizes flexing and helps to avoid cracking paint and smooths operation of hidden hinges.

T-16714-EDF	Braces	not.avbl
-------------	--------	----------

Hidden hinge and latch kit:

By DF Metalworks. Includes hinges, latches, and side panel lower alignment pins. Hardware and instructions are included.

A-16711-DF	LH Open	not.avbl
A-16711-DF2	2 Way Open	not.avbl

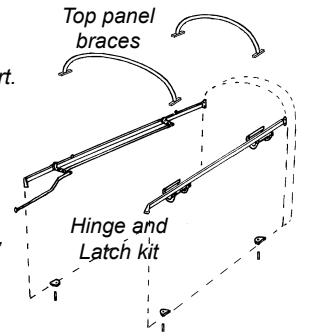

Center Hinge Hinge Brackets

Stock type: front or rear:

A-8220	For stock type round hinge rod	5.00 ea
	Chrome	

V8 Type: front or rear

B-8220	For reproduction hood w/V8 hinge	25.00 ea
	Chrome	

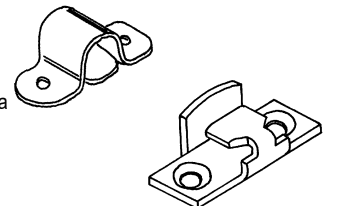

* Parts with price listed as "not.avbl" are not known to be available at this time, but are listed for reference.

1926-27 Radiator Shell, Hood, Fenders and Running Boards

Hood Latches and Hood Shelves

Top latches are original type, cast brass.
Hood shelves fill space between hood and fenders.

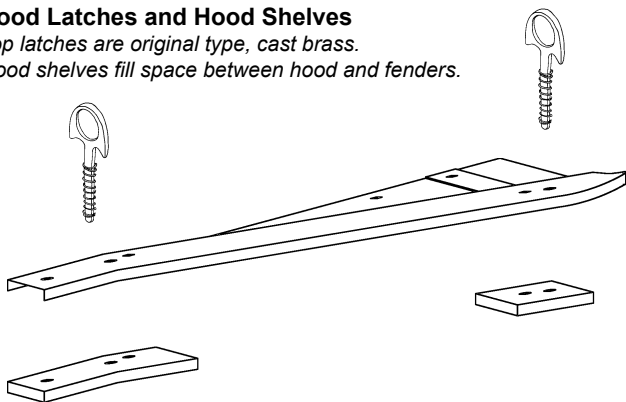

T-16750-BS	Hood Latches, Stock type, set of 4, brass w/springs	37.50 set
T-16713-S	Hood shelves (fender/hood spacers), stamped steel	not.avbl
T-16715-DS	Hood shelf wood block set, 4 pcs	30.00 set

Hood Lacing

We recommend fabric or hard rubber lacing for 4 piece hoods, foam rubber should only be used with 3 piece hoods.

T-16739-S	Radiator shell: Fabric original lace type	12.50 ea
T-16740-S	Cowl: Fabric, w/rivets	20.00 ea
HR-16739	Foam rubber, 3/8" x 3/16" (most rad shells)	15.00 ea
HR-16740	Foam rubber, 5/8" x 3/8" (most cowls)	25.00 ea

1926-27 Front Fenders, Fiberglass



RFF2627A	RH Front	500.00 ea
LFF2627A	LH Front	500.00 ea

1926-27 Rear Fenders, Fiberglass



RFF2627CR	RH Rear: Coupe, Roadster, PU	375.00 ea
LRF2627CR	LH Rear: Coupe, Roadster, PU	375.00 ea
RFF2627ST	RH Rear: Sedan & Touring	375.00 ea
LRF2627ST	LH Rear: Sedan & Touring	375.00 ea

1926-27 Fender Brackets

Front: Fits All Models

T-16025 100.00 ea

Rear: Coupe, Roadster, PU:

T-16180 not.avbl

Rear: Sedan and Touring:

T-16391-ST not.avbl

Bracket to Fender Bolts

Stainless Steel, 1/2" long

B-16026-S2 5.00 pr

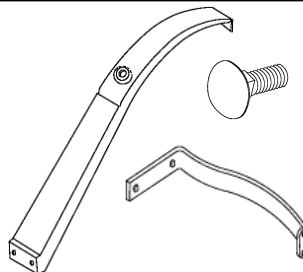

Fender Welt

Black vinyl, 25 ft. length

48-16070-B	3/16" bead	17.50 ea
48-16070-D	1/4" bead	17.50 ea

Vinyl, clad w/stainless bead, 8 ft. length

48-16070-SS	7/32" bead	30.00 ea
-------------	------------	----------

Vinyl, COLORED, Use part suffix to indicate color
Maroon: -MR, Caramel: -CR, Medium Blue: -BLM, Red: -RD, Dark Brown: -BRD, Dark Green: -GRD, White: -WH, Grey: -GY, Bright Orange: -OR, Yellow: -YL, Bright Red: -RR

48-16070-xx 25 ft length, Specify Color 40.00 ea

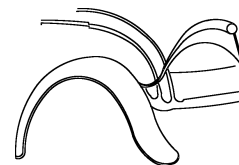

1926-27 Running Boards,

Stock style w/ diamond tread

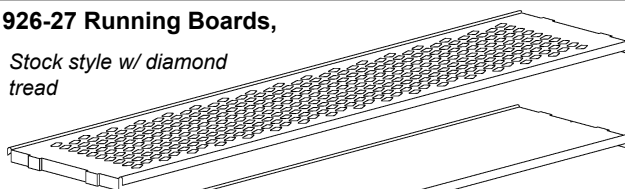

Smooth style



T-16450-S	Running boards, stock style, stamped steel	200.00 pr
T-16450-SM	Running boards, smooth style	175.00 pr
T-16455-MS	Mounting bolt set	7.50 set
T-16455-MW	Running board to bracket spacers, wood	17.50 set

1926-27 Running Board Splash Aprons

Stamped Steel

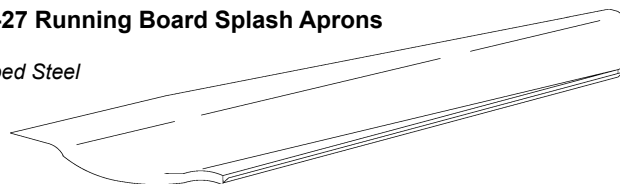

T-16532-S	Plain	250.00 pr
T-16532-LS	Louvered	350.00 pr

Custom Rear Rolled Pan

Fiberglass



RRP2627R6	6" deep, Roadster only	230.00 ea
-----------	------------------------	-----------

Special 1928-29 Style Rear Fenders for 1926-27 on "A" Frame

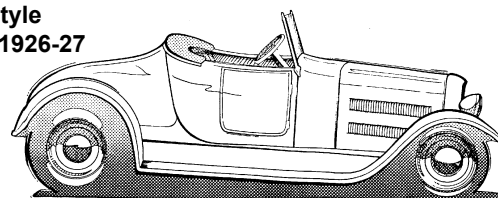

Special 1928-29 style rear fenders for 1926-27 Coupe or Roadster when using a 103 1/2" wheelbase Model A chassis. Use 1928 or 1929 Front fenders. Special length Model A style running boards and splash aprons must be used. Note a custom length hood must be used. Our 4 1/2" chop 1932 grille shell and custom front apron are a perfect match for these fenders.

RRF2627CRA	RH fender: Coupe, Roadster, PU, glas	375.00 ea
LRF2627CRA	LH fender: Coupe, Roadster, PU, glas	375.00 ea
A-16450-26SM	Running Boards, steel (x-long '28)	250.00 pr
A-16532-26S	Side splash aprons, steel (x-long '28)	225.00 pr



* Parts with price listed as "not.avbl" are not known to be available at this time, but are listed for reference.