

**1928-29
Radiator Shell, Hood,
Fenders and Running Boards**



1928-29 Radiator Shells

Stock style:

Has holes for radiator cap, emblem, crank, headlight and horn wiring. Emblem and crank cover sold separately.

A-8200-AC	Chrome	300.00	ea
A-8200-AP	Plain	not.avbl	

Smoothie style, no holes:



A-8200-ASM	Plain	400.00	ea
A-8200-ACM	Chrome	375.00	ea

Emblem, Crank cover, and bolts

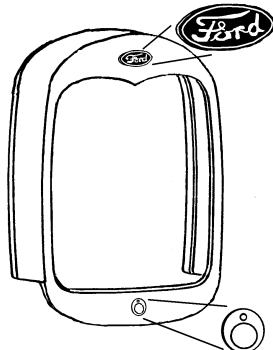
A-8212-A	1928-30 Ford Emblem: Chrome w/blue back	40.00	ea
A-8216-A	1928-29 Crank Hole Cover, Stainless Steel	7.50	ea
A-8201-AM	1923-29 Radiator Shell Mount Bolt Set	not.avbl	

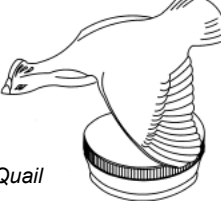

1928-29 Radiator Caps

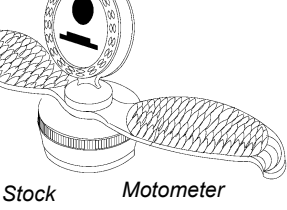
				
	<i>Quail</i>	<i>Stock</i>	<i>Motometer</i>	
A-8100-A	Original style, screw on mount		32.50	ea
A-18535-A	Quail style, chrome, base locks with setscrew		75.00	ea
Motometers:	Chrome	Brass		
Motometer:	B-18354-CW	55.00 ea	B-18354-BW	55.00 ea
Motometer wings:	A-18355-WC	30.00 ea	A-18355-WB	22.50 ea
Locking radiator cap:	A-18360-A	45.00 ea		

1928-29 Front Splash Apron, For 1928-29 Radiator Shell.

			
FSA2829A	Stock style, fiberglass		200.00 ea
A-18527-A	Stock style, stamped steel		not.avbl
FSA2829AB	Bubbled, for cars using front mounted rack & pinion steering, fiberglass		200.00 ea

Radiator Stone Guards

Chrome plated grille work. Helps protect radiator from large road debris.

Mounts to radiator shell with clips into headlight wire holes.

A-18700-A	165.00	ea
-----------	--------	----

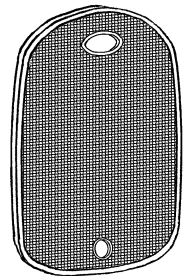

1932 Grille Shells for 1928-29

Wescott's makes a special 1932 grille shell with an extended inner lower tank shield to fit 1928-29's. Requires use of a 3" chopped 1932 radiator and a special hood. Full fendered cars require a special front splash apron. Hood shelves are not used.

Note: the grille is NOT chopped, the sides of the shell are trimmed to allow the shell to drop lower on the frame. Order grille in 1932 section

Grille shell for 1928-29, fiberglass

<i>Fiberglass</i>	
GS32PFE	400.00 ea

Special Front Apron, fiberglass

<i>For fendered 1928-29 using 1932 grille</i>	
FSA2829A2	230.00 ea



* Parts with price listed as "not.avbl" are not known to be available at this time, but are listed for reference.

1928-29 Radiator Shell, Hood, Fenders and Running Boards, cont

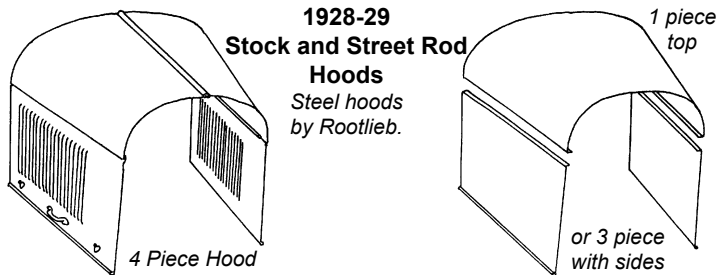

1928-29 Stock and Street Rod Hoods
Steel hoods by Rootlieb.

1 piece top

or 3 piece with sides

Hood top includes center hinge. (We recommend the V8 hinge on street rods for ease of opening and to help prevent paint chipping).

Hood top can be used a top panel only. Side panels do not have handles.

Side panels are complete with hood handles and hinge rods.

Hood hinges and top panel braces not included, sold separately.

Hood Tops

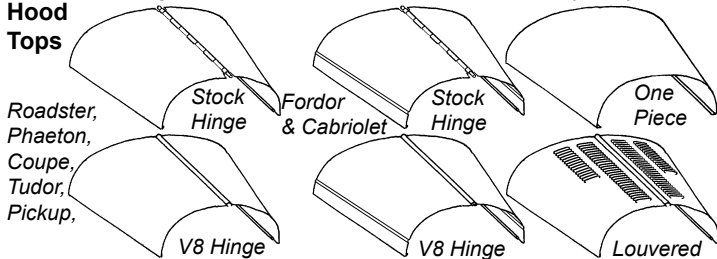

4 Piece style

	Coupe, Roadster, etc	Fordor & Cabriolet
Stock Hinge, plain	A-16710-A 270.00 ea	A-16710-B 270.00 ea
V8 Hinge, plain	A-16710-A2 295.00 ea	A-16710-B2 295.00 ea
V8 Hinge, louvered	A-16710-A2L 425.00 ea	

One Piece Top

	Cars w/ 28-29 Radiator	Cars w/ 1932 Grille
Top panel, plain	A-16710-A3 325.00 ea	29-16710-A3 325.00 ea
Top panel, louvered	A-16710-A3L 425.00 ea	29-16710-A3L 425.00 ea

Hood Sides

Early 1928 Louvers all same height

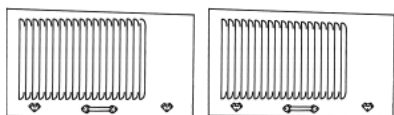

1928-29 Louvers match hood line

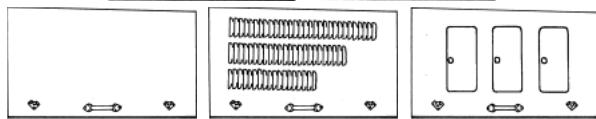

Plain

Hot Rod Louver

3 Door

Single scoop

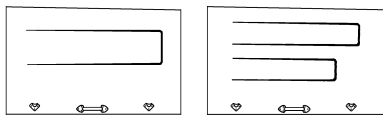

Double scoop

4 Piece style:

A-16712-A	Sides, Stock louver pattern	260.00 pr
A-16712-AR	Sides, Stock (early 1928 louvers)	270.00 pr
A-16712-AH	Sides, Hot rod louver pattern	270.00 pr
A-16712-AP	Sides, Plain, no louvers	270.00 pr
A-16712-AS1	Sides, Single scoop	450.00 pr
A-16712-AS2	Sides, Double scoop	600.00 pr
A-16712-AD	Sides, 3 Door	675.00 pr

3 Piece style

	1928-29 Radiator	1932 Grille Shell
Top panel, plain	A-16710-A3 325.00 ea	29-16710-A3 325.00 ea
Top panel, louvered	A-16710-A3L 425.00 ea	29-16710-A3L 425.00 ea
Sides, stock louver	A-16713-A 250.00 pr	29-16713-A 195.00 pr
Sides, hot rod	A-16713-AH 195.00 pr	29-16713-AH 195.00 pr
Sides, plain	A-16713-AP 195.00 pr	29-16713-AP 195.00 pr
Sides, single scoop	A-16713-AS1 525.00 pr	29-16713-AS1 525.00 pr
Sides, double scoop	A-16713-AS2 850.00 pr	29-16713-AS2 850.00 pr

Hood Hinge (Stock Rod Style)

Front Bracket: Chrome

A-8220 5.00 ea

Rear Bracket: Plain

A-16735-A 10.00 ea

Rods, Stainless, set of 3

A-16631-AS 50.00 set

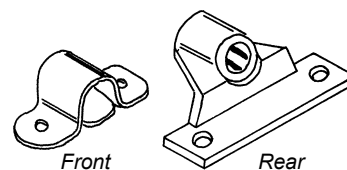

Front

Rear

Hood Hinge (V8 Strip Style)

Use front or rear. Fabricate a spacer for rear bracket using a stock cowl top.

B-8220 25.00 ea

Replacement Center Strip, Stainless

B-16632 17.50 ea

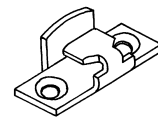

1928-36 Accessory Hood Supports

Stainless Steel. Mounts to radiator support rods.

HR-16780-SS 45.00 ea

Hood Latches and Hood Shelves

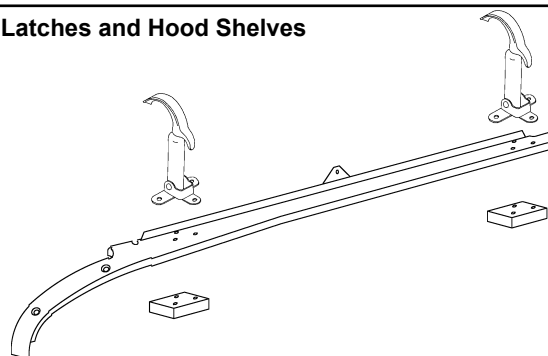

Hood Latches and accessories

A-16750-A	Hood latch, Plain	27.50 ea
A-16750-AC	Hood latch, Stainless	35.00 ea
A-16750-PA	Hood latch base pads	10.00 set
A-16750-CA	Hood latch tip and end caps	5.00 set
A-16750-MS	Hood latch mounting screws, stainless	5.00 set

1928-29 Hood Shelves

A-16713-S	Hood shelves, stamped steel, excellent quality	130.00 pr
A-16715-S	Hood shelf wood block set	27.50 set
A-16713-MS	Hood shelf to fender screws, stainless	5.00 set

Hood Side Hardware and Bumpers

A-16636	Hood side handles, Plain, w/rivets	25.00 pr
A-16636-SS	Hood side handles, Stainless, w/screws	35.00 pr
A-16751-S	Hood latch catch brackets, set of 4	20.00 set
A-16751-RS	Dummy (threaded) rivets, chrome, set of 20	10.00 set
A-16761-A	Hood bumper set	15.00 set
A-16622-LS	Leather corner protectors	5.00 pr
A-16622-RS	Rubber corner protectors	5.00 pr

Hinges and Braces for 3-Piece Hoods

Top Panel Braces

3/8" round steel braces provide extra support.

This minimizes flexing and helps to avoid cracking paint and smooths operation of hidden hinges.

A-16714-ADF	1929 shell	not.avbl
A-16714-ADFH	1932 shell	not.avbl

Hidden hinge and latch kit:

By DF Metalworks. Includes hinges, latches, and side panel lower alignment pins.

Hardware and instructions are included.

A-16711-DF	LH Open	not.avbl
A-16711-DF2	2 Way Open	not.avbl

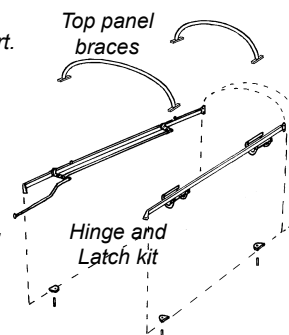

Top panel braces

Hinge and Latch kit

* Parts with price listed as "not.avbl" are not known to be available at this time, but are listed for reference.

1928-29 Radiator Shell, Hood, Fenders and Running Boards, cont

Hood Lacing

We recommend fabric or hard rubber lacing for 4 piece hoods, foam rubber should only be used with 3 piece hoods.

A-16739-AS	Radiator shell, Fabric w/rivets	17.50 ea
A-16740-AS	Cowl, Fabric, w/rivets (economy version)	25.00 ea
A-16740-ARS	Cowl, Fabric w/wire, exact reproduction	27.50 ea
HR-16739	Foam rubber, 3/8" x 3/16" (most rad shells)	15.00 ea
HR-16740	Foam rubber, 5/8" x 3/8" (most cowls)	25.00 ea

Front Fenders, Early 1928 Style, Fiberglass

Both early 1928 style and 1928-29 style fit all 1928-29's

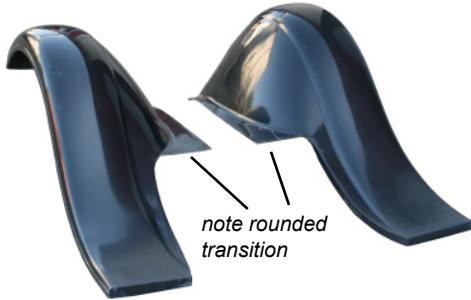

RFF28AR	RH plain, early 1928 style	500.00 ea
LFF28AR	LH plain, early 1928 style	500.00 ea

Front Fenders, 1928-29 Style, Fiberglass

Both early 1928 style and 1928-29 style fit all 1928-29's

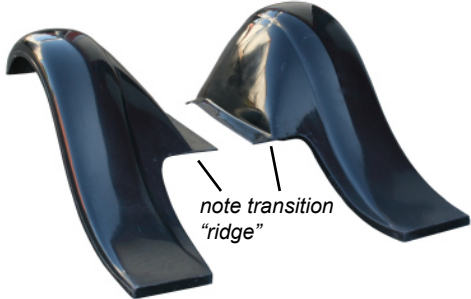

RFF2829A	RH plain, 1928-29 style	500.00 ea
LFF2829A	LH plain, 1928-29 style	500.00 ea

Front Fenders with Spare Tire Well, Fiberglass



RFF2829AW6	RH w/stock 6" wide tire well (1928-29 style)	625.00 ea
LFF2829AW6	LH w/stock 6" wide tire well (1928-29 style)	625.00 ea
RFF2829AW8	RH w/8" wide tire well (1928-29 style)	625.00 ea
LFF2829AW8	LH w/8" wide tire well (1928-29 style)	625.00 ea

Fender Welt

Black vinyl, 25 ft. length		
48-16070-B	3/16" bead	17.50 ea
48-16070-D	1/4" bead	17.50 ea

Vinyl, clad w/stainless bead, 8 ft.		
48-16070-SS	7/32" bead	30.00 ea

Vinyl, COLORED, Use part suffix to indicate color

Maroon: -MR, Caramel: -CR, Medium Blue: -BLM, Red: -RD, Dark Brown: -BRD, Dark Green: -GRD, White: -WH, Grey: -GY, Bright Orange: -OR, Yellow: -YL, Bright Red: -RR		
48-16070-xx	25 ft length, Specify Color	40.00 ea

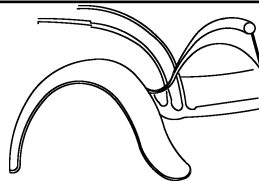

Front Fender Brackets

Stamped Steel

Bracket, fits all models

A-16025-AS	RH or LH	65.00 ea
------------	----------	----------

Fender to fender bracket bolt

B-16026-S2	Stainless	5.00 pr
------------	-----------	---------

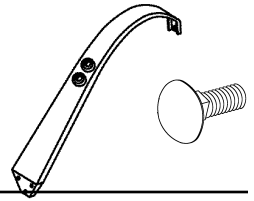

Rear Fenders

Coupe, Roadster, Cabriolet & Pickup

Fiberglass:

RRF2829CR	RH	375.00 ea
LRF2829CR	LH	375.00 ea

Steel:

Steel fenders may require expert bodywork for perfect fit.

A-16160-A	RH	not.avbl
A-16161-A	LH	not.avbl



Rear Fenders

Tudor, Fordor, Victoria

Fiberglass:

RRF2829SPH	RH	375.00 ea
LRF2829SPH	LH	375.00 ea



Rear Fender Brackets

Stamped Steel

A-16391-C	Bracket: Coupe, Roadster, Pickup	25.00 ea
A-16391-AS	Bracket: Sedan & Phaeton	not.avbl
B-16026-S2	Fender to bracket bolts, stainless	5.00 pr



Rear Wheelwell Studs

Large head fender mount bolt, spot welds to wheelwell of steel body.

AH-1173	Set of 4	1.00 ea
---------	----------	---------

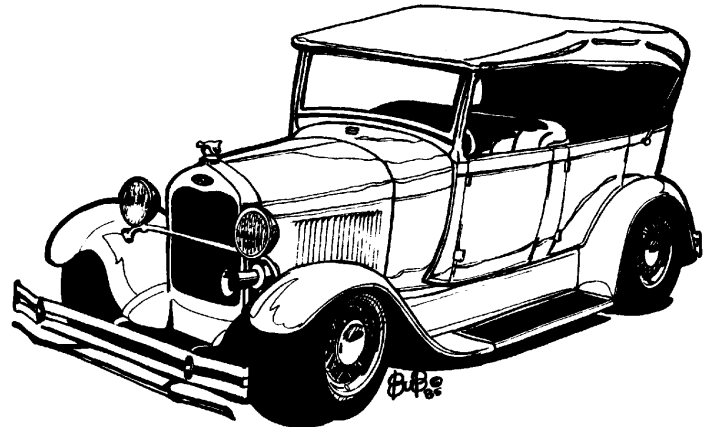
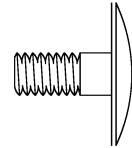

* Parts with price listed as "not.avbl" are not known to be available at this time, but are listed for reference.

1928-29 Radiator Shell, Hood, Fenders and Running Boards, cont

Running Boards Passenger Style

Stamped steel w/ribbed rubber mat. Stainless trim around all 4 edges.

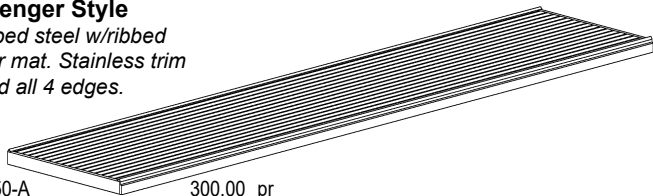

A-16450-A 300.00 pr

Running Boards Commercial Style

Stamped steel with diamond tread pattern. Ford script.

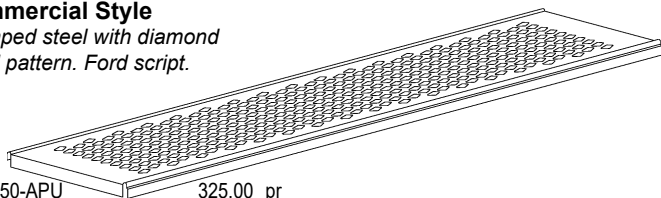

A-16450-APU 325.00 pr

Running Boards Smoothie Style

Stamped steel, no tread.

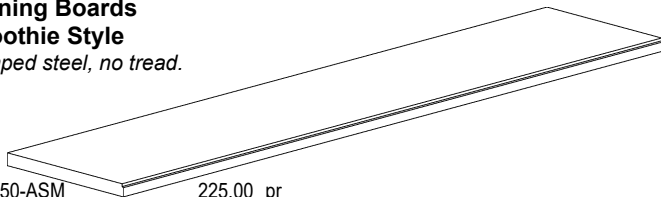

A-16450-ASM 225.00 pr

Running Board Splash Aprons

In mid 1928 Ford added a small hump on the side apron just ahead of the rear fender to clear a new design brake cross shaft.

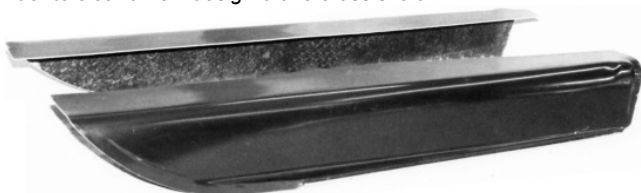

RSA2829A	RH, fiberglass, w/hump	300.00 ea
LSA2829A	LH, fiberglass, w/hump	300.00 ea
A-16532-AR	Steel, w/o hump (early 1928)	250.00 pr

Running Board Brackets

Bracket, Front:

A-5125 RH or LH 45.00 ea

Bracket, rear:

A-5130 RH 45.00 ea

A-5131 LH 45.00 ea

Bracket to board "hat" head bolts

A-16455-MS Set of 8 10.00 set

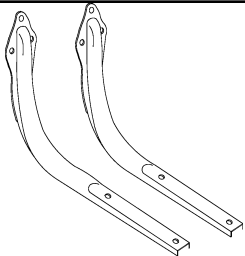

Running Board Trim & Rubber Mats

A-16461-A2 Trim, stainless, 8 piece set 70.00 set

A-16450-RM Mat, rubber, ribbed design 40.00 pr

1928-29 Back Lower Splash Panel, Fiberglass



BP2931BS 1929 Briggs fordor sedan 230.00 ea
(Briggs bodies have straight top on door windows)

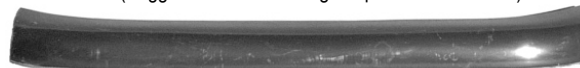

BP2930MS 1929 Murray fordor sedan 230.00 ea
(Murray bodies have arched top on door windows)

Custom Rear Rolled Pans, Fiberglass

3" Deep Coupe & Roadster



6" Deep

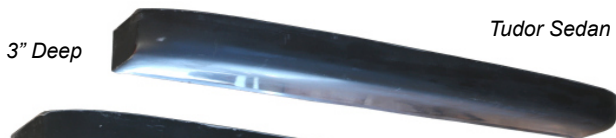

Tudor Sedan



6" Deep

RRP2831CR3	3" deep, Coupe & Roadster	300.00 ea
RRP2831CR6	6" deep, Coupe & Roadster	300.00 ea
RRP2831ST3	3" deep, Tudor sedan	300.00 ea
RRP2831ST6	6" deep, Tudor sedan	300.00 ea

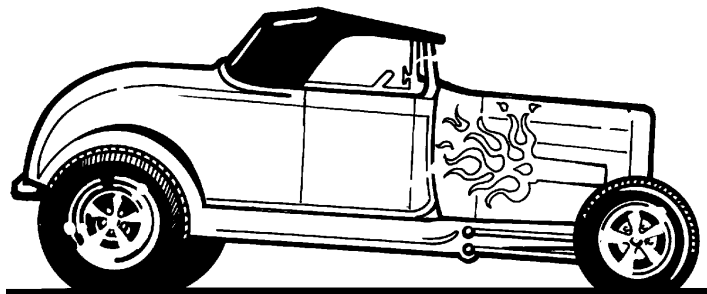
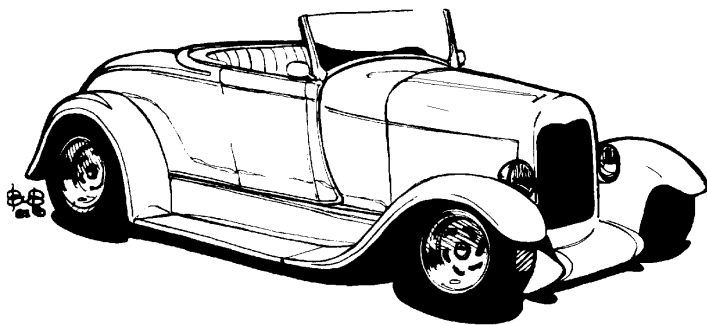

* Parts with price listed as "not.avbl" are not known to be available at this time, but are listed for reference.