

Body to Frame Mounting

1928-31 Body to Frame Wood Spacer Block & Bolts

1926-31 steel framed bodies (Coupes, Tudors, Pickups, Fordor phaetons) used wood blocks inside the subframe channels to properly space the body. Wood framed bodies (Fordor sedans, Cabriolets, and Victorias) had solid wood sills and did not use a separate block. Thin rubberized fabric pads went between the wood and the frame. Replacement rubber pads are available or fabric chassis welt can be used. Note: Some modifications to the wood blocks are needed when fitting to fiberglass bodies.

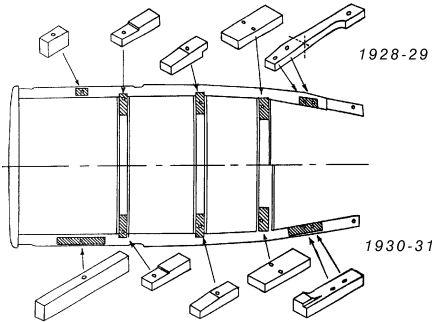

TWD-1065	1926-27 Coupe & Roadster	105.00	ea
TWD-1066	1926-27 Touring	95.00	ea
AWD-1005	1928-29 Coupe & Roadster	70.00	set
AWD-1006	1928-29 Pickup cab	55.00	set
AWD-1007	1928-29 Tudor sedan	80.00	set
AWD-1015	1930-31 Pickup cab	55.00	set
AWD-1016	1930-31 Coupe & Roadster	70.00	set
AWD-1017	1930-31 Tudor sedan	80.00	set
AWD-1018	1931 Slant Windshield Fordor	130.00	ea
A-80045	Body to frame bolt set, 1928-31 passenger	not.avbl	
A-5000-P	Frame to wood block rubber pad set	12.50	set

1928-31 Body Bolts and Washers for wood sill cars

Fordors, Victorias, Cabriolets

A-5006	Special large washer with square hole	10.00	ea
A-5007	Special large washer with round hole	7.50	ea
A-80045	Body to frame bolt set, 1928-31 passenger	not.avbl	

1926-34 Body to Frame Treated Fabric Welt

R-3404-FW	1/8" thick, 25 ft roll	40.00	ea
R-3404-ST	1/8" thick, 25 ft, self sticking	50.00	ea

1932-34 Passenger Body to Frame Spacers

1932-34 cars used the thin rubber pads between the body and the frame. We recommend using the fabric chassis welt on these years.

1932-47 Pickup Cab to Frame Wood Block Sets

1932-47 Pickups used wood spacer blocks with the thin rubber pads between the wood and the frame. Use the A-5000-P pad kit or fabric chassis welt.

VWD-1002	1932 Pickup Cabs	200.00	set
VWD-1003	1933-34 Pickup cabs	170.00	set
VWD-1004	1935-37 Pickup cabs	350.00	set
VWD-1004-T	1935-37 1 1/2 ton truck	not.avbl	
VWD-1006	1938 Pickup cabs	425.00	set
VWD-1008	1939-41 Pickup cabs	550.00	set
VWD-1010	1942-47 Pickup Cabs	200.00	set
A-5000-P	Frame to wood block rubber pad set	12.50	set

1937-48 Body to Frame Bolt Sets

78-5000-HK	1937-40 Passenger	45.00	set
51A-5000-HK	1941-48 Passenger	45.00	set

1935-36 Passenger

Body to Frame Pad Sets

1935-36 cars used a combination of rubber and rubberized cork pads with varying thicknesses.

48-5001 95.00 kit

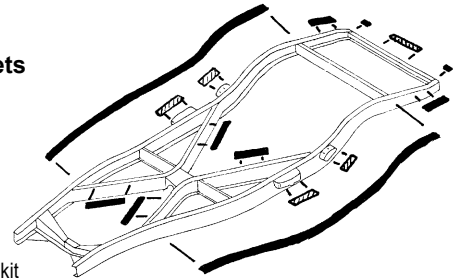

Center Floorpan to Frame Wood Support Strips

48-5001-W5

155.00 pr

1937-40 Body to Frame Pad Sets

1937-40 cars used rubber pads approx. 1/4" thick.

We recommend 1937-40 Convertibles use steel pads at the cowl and door post as the rubber pads allow too much cowl flex for door alignment.

1940 Convertible used combination thick steel and thin rubber pads. The replacement kit does not include the steel pads. Steel pad size is 1/4 x 1-1/2 x 2.

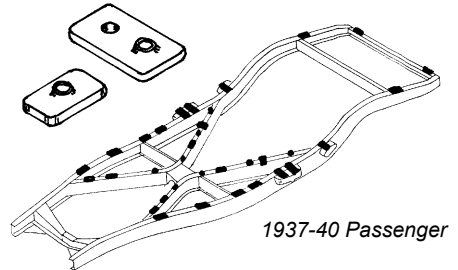

1937-40 Passenger

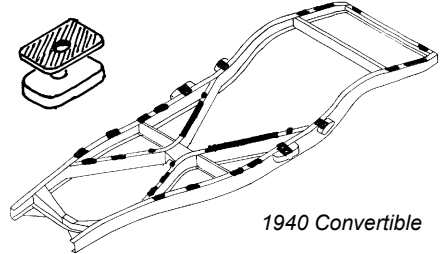

1940 Convertible

78-5001	1937-40 Passenger	55.00	set
01A-5001-C	1940 Convertible	70.00	kit

1941-48 Passenger Body to Frame Pad Sets

11A-5001	1941 Coupe & Sedan	45.00	kit
11A-5001-C	1941 Convertible	45.00	kit
21A-5001	1942-48 Passenger	40.00	set

1948-52 Pickup Cab to Frame Mounting

7C-5400-SS	Rubber pad and bushing set	30.00	kit
7C-5352	Cab to frame arm	25.00	ea
7C-5404-KIT	Cab to frame bolts	37.50	ea

1948-52 Pickup Cab to Frame Mounting

BAAA-5400-S	Rubber pad and bushing set	22.50	kit
BAAA-8102058-PR	Cab front mount upper cups	35.00	pr
BAAA-8102060-PR	Cab front mount lower cups	15.00	pr
7C-5352	Cab to frame arm	25.00	ea
BAAA-5404-KIT	Cab to frame bolts	25.00	ea

* Parts with price listed as "not.avbl" are not known to be available at this time, but are listed for reference.

Frame and Chassis Components

1928-31 Body and Hood Latch Mount Brackets on Frame

A-5074-S	Hood rear latch brackets	17.50 ea
A-5075-S	Body cowl mount brackets	27.50 ea

1932 Frame Horn Repair Members, steel

Rear: 24" long

B-158	125.00 pr
-------	-----------

Front: 20" long

B-158-F	125.00 pr
---------	-----------

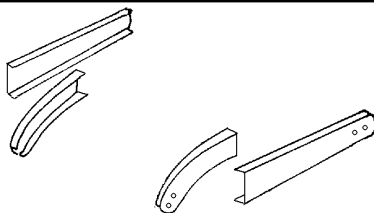

1932 Frame Spreader Bars

Front, stainless

B-5041-SS	65.00 ea
-----------	----------

Rear, straight, stainless

B-18575-SB	105.00 ea
------------	-----------

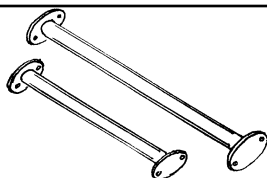

1933-34 Frame Horn Repair Members, steel

40-158-F	Front	115.00 pr
40-158-R	Rear	115.00 pr

1933-34 Frame Rear Spreader Bars

Steel, with inner brackets for mounting bumper

40-18575-PS	Also has inner support for spare tire bracket	not.avbl
40-18575-PO	No spare tire support	225.00 ea

1935-40 Frame Repair Parts

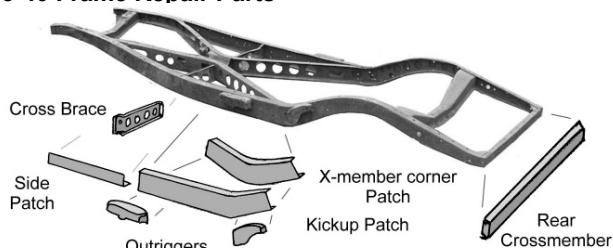

Frame side patch (36" x 4" x 2" x 11ga):

48-5006-P11	Any	65.00 ea
-------------	-----	----------

Frame Kickup Patch, 11 ga

48-5006-K11R	RH	175.00 ea
--------------	----	-----------

48-5006-K11L	LH	175.00 ea
--------------	----	-----------

Frame X-Member rear corner patch:

48-5006-XR	RH	175.00 ea
------------	----	-----------

48-5006-XL	LH	175.00 ea
------------	----	-----------

Frame outriggers (body mounts):

48-5084	RH Front	175.00 ea
---------	----------	-----------

48-5085	LH Front	175.00 ea
---------	----------	-----------

48-5086	RH Rear	175.00 ea
---------	---------	-----------

48-5087	LH Rear	175.00 ea
---------	---------	-----------

Frame X-member to side rail brace:

48-5048	RH, 1935-36	175.00 ea
---------	-------------	-----------

48-5049	LH, 1935-36	175.00 ea
---------	-------------	-----------

78-5048	RH, 1937-38	175.00 ea
---------	-------------	-----------

78-5049	LH, 1937-38	175.00 ea
---------	-------------	-----------

91A-5048	RH, 1939-40	175.00 ea
----------	-------------	-----------

91A-5049	LH, 1937-40	175.00 ea
----------	-------------	-----------

48-5165	Battery support 1935-36	100.00 ea
---------	-------------------------	-----------

Frame rear crossmember:

48-5035	125.00 ea
---------	-----------



1935-40 Convertible Hinge Post Mount Support

Mounts between frame rail and crossmember at door hinge post.

48-5090	RH, 1935-40 Convertible	150.00 ea
48-5091	LH, 1935-40 Convertible	150.00 ea

Original Type Battery Supports

A-5151	1928-31 Battery support frame	35.00 ea
B-5151	1932 Battery support frame	30.00 ea
40-5151	1933-34 Battery support frame	30.00 ea
78-700740	1937-39 battery box in firewall	155.00 ea
01A-5151	1940 Battery support frame (on fender)	40.00 ea
7C-5151	1948-52 V8 Pickup battery tray	80.00 ea
BAAA-5151	1953 Pickup	60.00 ea
B4C-5151	1954-55 Pickup	60.00 ea
40-5165	1933-53 Battery hold down frame	10.00 ea

Front Axle Bumpers

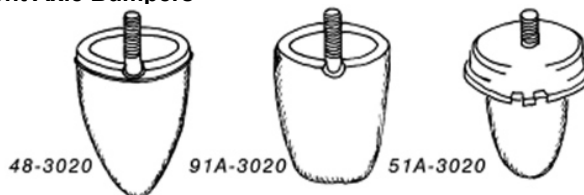

B-3020	1932-34, Mounts to spring plate	not.avbl
48-3020	1935-38, Molded rubber w/stud	15.00 ea
91A-3020	1939-40 Pass, 39-41 PU, molded rubber w/stud	40.00 pr
11A-3020	1941-42 Pass, molded rubber	10.00 ea
21C-3020	1942-47 Pickup	10.00 ea
51A-3020	1946-48 Pass, molded rubber	25.00 ea

Rear Axle Bumpers

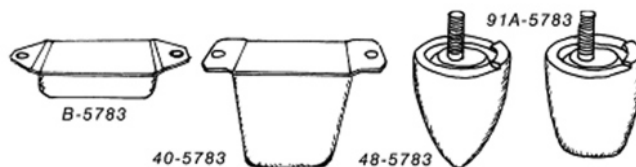

AA-5783-K	1928-47 1-1/2 ton truck	160.00 pr
B-5783	1932, Rubber w/steel backing	7.50 ea
40-5783	1933-34, Rubber w/steel backing	10.00 ea
48-5783	1935-38, Molded rubber w/stud	40.00 pr
91A-5783	1939-40 Pass, 39-41 PU, molded rubber w/stud	40.00 pr
11A-3020	1941-48 Pass, 42-47 PU, molded rubber	10.00 ea

Front Axle Wishbone Ball Bushing

B-3446	1932-40 All, molded neoprene	12.50 ea
11A-3446	1941-48 Passenger	not.avbl

Spring Shackles Street Rod Type



	Plain		Stainless	
Fits 1-3/4" spring	H-5304-A	not.avbl	H-5304-AS	75.00 pr
Fits 2" springs	H-5304-B	50.00 pr	H-5304-BS	75.00 pr
Fits 2 1/4" springs	H-5304-C	not.avbl	H-5304-CS	not.avbl

* Parts with price listed as "not.avbl" are not known to be available at this time, but are listed for reference.

Frame and Chassis Components, cont

Street Rod Spring Liners, Polypropylene

Black, slippery polypropylene.

Used between spring leaves helps spring work freely and may give a softer ride. The channel shape helps keep the spring liner in place.

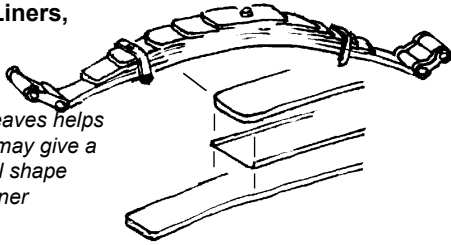

H-5305-A	Fit 1 3/4" springs	17.50 ea
H-5305-B	Fit 2" springs	17.50 ea
H-5305-C	Fit 2 1/4" springs	20.00 ea

Street Rod Spring Clamps, Stainless Steel



H-5330-AS	Fit 1 3/4" springs	40.00 pr
H-5330-BS	Fit 2" springs	40.00 pr
H-5330-CS	Fit 2 1/4" springs	40.00 pr

1939-40 Parking Brake Cables & Parts

91A-2271	1939-40 Park brake cable guides	7.50 pr
91A-2272	1939-40 Park brake cable guide brackets	7.50 pr
91A-2273	1939-40 Pk bke cable frame grommet	5.00 ea
91A-2275	1939-40 Park brake cable	22.50 ea
21A-2275	1941-48 Park brake cable	25.00 ea
91A-2597	1939-40 Park brake cable boots	15.00 pr

Steering Column Upper Shaft Rubber Bushing

B-5317-N	1932-48 bushing with sleeve	27.50 ea
----------	-----------------------------	----------

Motor & Exhaust Accessories

Louvered Air Cleaner

Fits most 2 bbl Carburetors with 2-5/8" throat

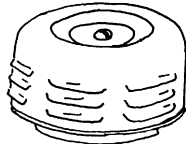

HR-9600-C4	20.00 ea
------------	----------

Exhaust Pipe End Deflectors

for original exhaust pipe

51A-18259-A	Ford script	20.00 ea
51A-18259-B	V8 script	20.00 ea
51A-18259-P	no script	20.00 ea



Flathead Motor Mounts

Each kit is for one motor mount, includes upper and lower cushions, cups, bolt, nut and washers.

B-6038-K	1932-36 Engine	27.50 ea
78-6039-K	1937-48 Passenger, 1937-51 Pickup also trans mount 1937-41 Pass & 1937-51 Pickup	25.00 ea

Flathead V8 Engine Parts

18-6067-CVR	11/16 Cylinder head nut covers, chrome, 50pc	not.avbl
18-6520-C	9/16" Intake manifold nut covers, chrome, 20pc	not.avbl
48-6750	V8-85 oil dipstick, chrome	17.50 ea

Hubcaps

Hubcaps, fit original 1928-29 or 1930-31 wheels

A-1130-B	1928-29 (Chrome)	15.00 ea
A-1130-C	1930-31 (Stainless)	30.00 ea

Hubcaps, Fit 1932-35 Ford & Kelsey Hayes Wire Wheels

S-1130-SS	1932 Style, no script	30.00 ea
B-1130-SS	1932 V8 script	30.00 ea
B-1130-BS	1932 "Ford" script	30.00 ea
18-1130-SS	1933 V8 script	30.00 ea
40-1130-BS	1933-34 "Ford" script	30.00 ea
40-1130-SS	1934 V8 script	30.00 ea
40-1130-P	1934 style, plain	30.00 ea
48-1130-SS	1935 V8 script	30.00 ea

Hubcaps, Fit 1936-39 Wide bolt pattern Wheels

68-1130-SS	1936 V8 Script	50.00 ea
------------	----------------	----------

Hubcaps For 1940-48 Ford Steel Wheels



01A-1130-C	1940 "Ford Deluxe"	30.00 ea
01A-1130-BM	1940 Deluxe, no script	30.00 ea
01C-1130-BM	1940 Standard, no script	not.avbl
11A-1130-BM	1941 no script	30.00 ea
21A-1130-BM	1942-48 no script	30.00 ea
01C-1130-SS	1940 "V8", Standard passenger, 1940-41 Pickup	30.00 ea
11A-1130	1941 Passenger "Ford"	30.00 ea
21A-1130	1942 Pass, 1946 Pickup "Ford"	30.00 ea
29A-1130-SS	1942 Mercury	75.00 ea
29A-1130-SM	1942-48 Mercury style, plain	55.00 ea
51A-1130	1946 Passenger "Ford"	30.00 ea
59A-1130-SS	1946 Mercury	75.00 ea
59A-1130-CS	1946-48 Mercury Canada version	75.00 ea
6A-1130-C	1947-48 Pass & 47-56 PU "Ford"	30.00 ea
6M-1130-SS	1947-48 Mercury	75.00 ea

Stainless Steel Beauty Rings

6A-18303-14	For 14" wheels, smooth	27.50 ea
01A-18303-14	for 14" wheels, ribbed	27.50 ea
8A-18303-14	for 14" wheels, convex	not.avbl
59A-18303-14	for 14" wheels, wave	not.avbl
6A-18303-15	For 15" wheels, smooth	27.50 ea
8A-18303-15	for 15" wheels, convex	45.00 ea
59A-18303-15	for 15" wheels, wave	45.00 ea
01A-18303-15	For 15" wheels, ribbed	27.50 ea
6A-18303-16	for 16" wheels, smooth	27.50 ea
01A-18303-16	For 16" wheels, ribbed	27.50 ea

* Parts with price listed as "not.avbl" are not known to be available at this time, but are listed for reference.