

Body to Frame Mounting

1928-31 Body to Frame Wood Spacer Block & Bolts

1926-31 steel framed bodies (Coupes, Tudors, Pickups, Fordor phaetons) used wood blocks inside the subframe channels to properly space the body. Wood framed bodies (Fordor sedans, Cabriolets, and Victorias) had solid wood sills and did not use a separate block.

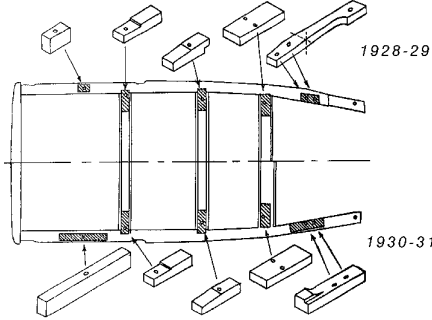

Thin rubberized fabric pads went between the wood and the frame. Replacement rubber pads are available or fabric chassis welt can be used. Note: Some modifications to the wood blocks are needed when fitting to fiberglass bodies.

TWD-1065	1926-27 Coupe & Roadster	37.50	ea
TWD-1066	1926-27 Touring	37.50	ea
AWD-1005	1928-29 Coupe & Roadster	60.00	set
AWD-1006	1928-29 Pickup cab	45.00	set
AWD-1007	1928-29 Tudor sedan	65.00	set
AWD-1015	1930-31 Pickup cab	45.00	set
AWD-1016	1930-31 Coupe & Roadster	60.00	set
AWD-1017	1930-31 Tudor sedan	65.00	set
AWD-1018	1931 Slant Windshield Fordor	75.00	ea
A-80045	Body to frame bolt set, 1928-31	7.50	set
A-5000-P	Frame to wood block rubber pad set	10.00	set

1928-31 Body to Frame Bolts

A-5000-HK	1928-31 Passenger	10.00	set
-----------	-------------------	-------	-----

1928-31 Body Bolt Washer for wood sill cars

Special large washer used only on the wood sill car (Fordors, Victorias, Cabriolets)

A-5006	with square hole	7.50	ea
A-5007	with round hole	7.50	ea

1928-31 Body and Hood Latch Mount Brackets on Frame

A-5074-S	Hood rear latch brackets	15.00	ea
A-5075-S	Body cowl mount brackets	20.00	ea

1926-34 Body to Frame Treated Fabric Welt

R-3404-FW	1/8" thick, 25 ft roll	25.00	ea
R-3404-ST	1/8" thick, 25 ft, self sticking	22.50	ea

1932-34 Passenger Body to Frame Spacers

1932-34 cars used the thin rubber pads between the body and the frame. We recommend using the fabric chassis welt on these years.

1932-47 Pickup Cab to Frame Wood Block Sets

1932-47 Pickups used wood spacer blocks with the thin rubber pads between the wood and the frame. Use the A-5000-P pad kit or fabric chassis welt.

VWD-1002	1932 Pickup Cabs	105.00	set
VWD-1003	1933-34 Pickup cabs	95.00	set
VWD-1004	1935-37 Pickup cabs	225.00	set
VWD-1004-T	1935-37 1 1/2 ton truck	40.00	set
VWD-1006	1938 Pickup cabs	250.00	set
VWD-1008	1939-41 Pickup cabs	325.00	set
VWD-1010	1942-47 Pickup Cabs	105.00	set
A-5000-P	Frame to wood block rubber pad set	10.00	set

Body to Frame Mounting, cont

1937-48 Body to Frame Bolt Sets

78-5000-HK	1937-40 Passenger	30.00	set
51A-5000-HK	1941-48 Passenger	30.00	set

1935-36 Passenger Body to Frame Pad Sets

1935-36 cars used a combination of rubber and rubberized cork pads with varying thicknesses.

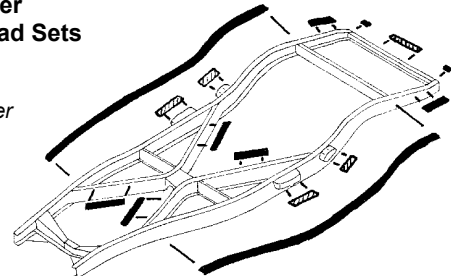

48-5001	80.00	kit
---------	-------	-----

1937-40 Body to Frame Pad Sets

1937-40 cars used rubber pads approx. 1/4" thick.

We recommend 1937-40 Convertibles use steel pads at the cowl and door post as the rubber pads allow too much cowl flex for door alignment.

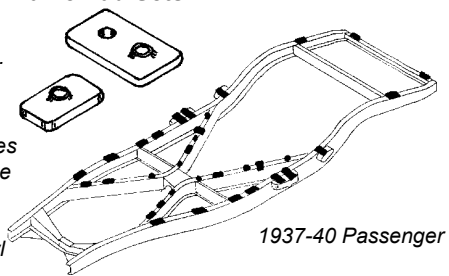

1940 Convertible used combination thick steel and thin rubber pads. The replacement kit does not include the steel pads. Steel pad size is 1/4 x 1-1/2 x 2.

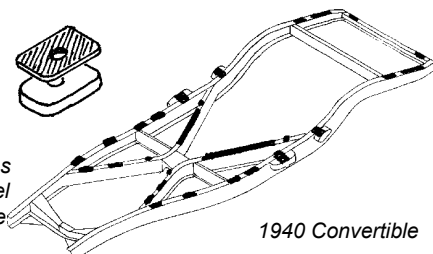

78-5001	1937-40 Passenger	40.00	set
01A-5001-C	1940 Convertible	45.00	kit

1941-48 Passenger Body to Frame Pad Sets

11A-5001	1941 Coupe & Sedan	40.00	kit
11A-5001-C	1941 Convertible	40.00	kit
21A-5001	1942-48 Passenger	40.00	set

1948-52 Pickup Cab to Frame Mounting

7C-5400-SS	Rubber pad and bushing set	25.00	kit
7C-5352	Cab to frame arm	25.00	ea
7C-5404-KIT	Cab to frame bolts	25.00	ea

1948-52 Pickup Cab to Frame Mounting

BAAA-5400-S	Rubber pad and bushing set	20.00	kit
BAAA-8102058-PR	Cab front mount upper cups	25.00	pr
BAAA-8102060-PR	Cab front mount lower cups	10.00	pr
7C-5352	Cab to frame arm	25.00	ea
BAAA-5404-KIT	Cab to frame bolts	25.00	ea

Frame & Chassis Components

1932 Frame Horn Repair Members, steel

Rear: 24" long

B-158 75.00 pr

Front: 20" long

B-158-F 100.00 pr

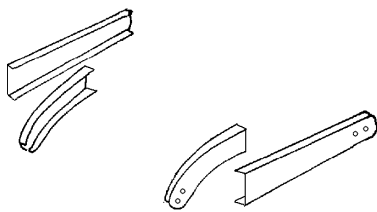

1932 Frame Spreader Bars

Front, stainless

B-5041-SS 65.00 ea

Rear, straight, stainless

B-18575-SB 105.00 ea

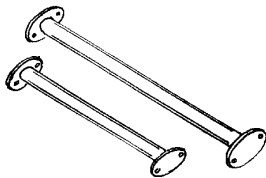

1933-34 Frame Horn Repair Members, steel

40-158-F	Front	105.00	pr
40-158-R	Rear	105.00	pr

1933-34 Frame Rear Spreader Bars

Steel, with inner brackets for mounting bumper

40-18575-PS	Also has inner support for spare tire bracket	145.00	ea
40-18575-PO	No spare tire support	145.00	ea

1935-40 Frame Repair Parts

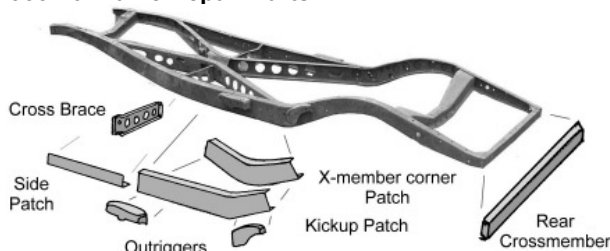

Frame side patch (36" x 4" x 2"):

48-5006-P11 11 gauge 45.00 ea

Frame Kickup Patch:

48-5006-K11R RH, 11 gauge 150.00 ea

48-5006-K11L LH, 11 gauge 150.00 ea

Frame X-Member rear corner patch:

48-5006-XR Right side 150.00 ea

48-5006-XL Left side 150.00 ea

Frame outriggers (body mounts):

48-5084 Right Front 150.00 ea

48-5085 Left Front 150.00 ea

48-5086 Right Rear 150.00 ea

48-5087 Left Rear 150.00 ea

Frame X-member to side rail brace:

48-5048 RH, 1935-36 150.00 ea

48-5049 LH, 1935-36 150.00 ea

78-5048 RH, 1937-38 150.00 ea

78-5049 LH, 1937-38 150.00 ea

91A-5048 RH, 1939-40 150.00 ea

91A-5049 LH, 1937-40 150.00 ea

48-5165 Battery front support: 1935-36 75.00 ea

Frame rear crossmember:

48-5035 1935-40 100.00 ea

1935-40 Convertible Hinge Post Mount Support

Mounts between frame rail and crossmember at door hinge post.

48-5090 RH, 1935-40 Convertible 90.00 ea

48-5091 LH, 1935-40 Convertible 90.00 ea

Frame & Chassis Components, cont

Original Type Battery Supports

A-5151	1928-31 Battery support frame	50.00	ea
B-5151	1932 Battery support frame	25.00	ea
40-5151	1933-34 Battery support frame	30.00	ea
78-700740	1937-39 battery box in firewall	150.00	ea
01A-5151	1940 Battery support frame (on fender)	32.50	ea
7C-5151	1948-52 V8 Pickup battery tray	80.00	ea
BAAA-5151	1953 Pickup	60.00	ea
B4C-5151	1954-55 Pickup	60.00	ea
40-5165	1933-53 Battery hold down frame	10.00	ea

Front Axle Bumpers



B-3020	1932-34, Mounts to spring plate	12.50	ea
48-3020	1935-38, Molded rubber w/stud	10.00	ea
91A-3020	1939-40 Pass, 39-41 PU, molded rubber w/stud	12.50	ea
11A-3020	1941-42 Pass, molded rubber	10.00	ea
21C-3020	1942-47 Pickup	10.00	ea
51A-3020	1946-48 Pass, molded rubber	10.00	ea

Rear Axle Bumpers

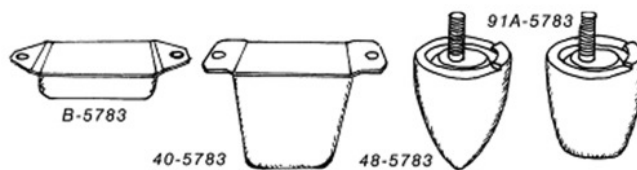

B-5783	1932, Rubber w/steel backing	7.50	ea
40-5783	1933-34, Rubber w/steel backing	10.00	ea
48-5783	1935-38, Molded rubber w/stud	10.00	ea
91A-5783	1939-40 Pass, 39-41 PU, molded rubber w/stud	10.00	ea
11A-3020	1941-48 Pass, 42-47 PU, molded rubber	10.00	ea

Kingpin & Bushing Sets

48-3111	1935-36 Car & Pickup	170.00	set
78-3111	1937-41 Car & Pickup	50.00	set
78-3111-SS	1937-41 Car & Pickup, w/stainless top	n.a	
21A-3111	1942-48 Car	55.00	set
21A-3111-SS	1942-48 Car with stainless top	n.a	

Front Axle Wishbone Ball Bushing

B-3446	1932-40 All, molded neoprene	12.50	ea
11A-3446	1941-48 Passenger	12.50	ea

Street Rod Spring Shackles



H-5304-A	Plain: fit 1 3/4" springs	45.00	pr
H-5304-AS	Stainless: fit 1 3/4" springs	70.00	pr
H-5304-B	Plain: fit 2" springs	45.00	pr
H-5304-BS	Stainless: fit 2" springs	70.00	pr
H-5304-C	Plain: fit 2 1/4" springs	45.00	pr
H-5304-CS	Stainless: fit 2 1/4" springs	70.00	pr

Frame & Chassis Components, cont

Street Rod Spring Liners, Polypropylene

Black, slippery polypropylene. Used between spring leaves helps spring work freely and may give a softer ride. The channel shape helps keep the spring liner in place.

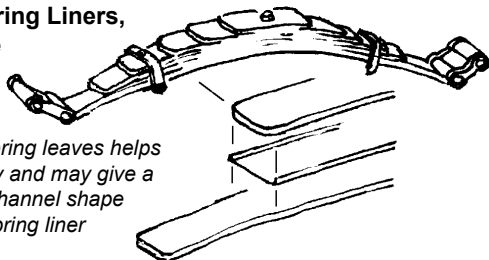

H-5305-A	Fit 1 3/4" springs	12.50	ea
H-5305-B	Fit 2" springs	12.50	ea
H-5305-C	Fit 2 1/4" springs	15.00	ea

Street Rod Spring Clamps, Stainless Steel



H-5330-AS	Fit 1 3/4" springs	35.00	pr
H-5330-BS	Fit 2" springs	35.00	pr
H-5330-CS	Fit 2 1/4" springs	35.00	pr

1939-40 Parking Brake Cables & Parts

91A-2271	1939-40 Park brake cable guides	7.50	pr
91A-2272	1939-40 Park brake cable guide brackets	7.50	pr
91A-2273	1939-40 Pk bke cable frame grommet	5.00	ea
91A-2275	1939-40 Park brake cable	20.00	ea
21A-2275	1941-48 Park brake cable	20.00	ea
91A-2597	1939-40 Park brake cable boots	22.50	pr

Steering Column Upper Shaft Rubber Bushing

B-3517	1932-48 bushing only	7.50	ea
B-3517-N	1932-48 bushing with sleeve	22.50	ea

Clutch, Brake & Gas Pedal

Clutch and Brake Pedal Pads

B-2454	1932, Ford script, 7/16-20 stud	40.00	ea
40-2454	1933-36, 1/2-18 stud	17.50	ea
78-2454	1937-40, 1/2-18 stud	17.50	ea
11A-2454	1941-48 Passenger, 1941-56 Pickup	10.00	ea

Street Rod Brake Pedal Pad

Stainless with rubber insert

HB-2454-SS	Uses original 1933-48 style taper stud	40.00	ea
HB-2454-SS-1	Uses 1/2"-20 stud, includes nut	40.00	ea

Gas Pedals, Rubber Covered

48-9735	1935-48 Passenger, 1935-47 Pickup	12.50	ea
TAAA-9735-A	1948-56 Pickup	12.50	ea

Gas Pedal Rod Rubber Boot

7C-8112177	1948-52 Pickup	25.00	ea
------------	----------------	-------	----

Rear Spare Tire Carrier

Rear Spare Tire Brackets

1928-29 Coupe & Roadster:			
A-1379-A	Aluminum,	80.00	ea
1928-31 Tudor Sedan & 4d Phaeton:			
A-1380-A	Aluminum,	80.00	ea
1930-31 Coupe & Roadster			
A-1379-BA	Aluminum	80.00	ea

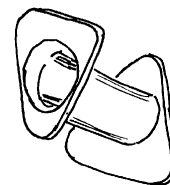

Spare Tire Bracket Studs

A-1448	1928-31 Wheel studs	2.50	ea
A-1449	1928-31 Bracket to body studs	5.00	ea

1928-31 Spare Tire Mount Blank Off Kit

Includes 2 large head screws and a plug button for filling the spare tire mount holes in the rear body panel.

A-1380-BO	kit	7.50	set
-----------	-----	------	-----

Spare Tire Cover Parts

40-1350	Trim ring: 1933-34 Passenger	90.00	ea
48-1350	Trim ring: 1935-36 Passenger	90.00	ea
40-1350-S	Cover rubber seal: 1933-36 Passenger	10.00	ea

Motor & Exhaust Accessories

Louvered Air Cleaner

Fits most 2 bbl Carburetors with 2-5/8" throat

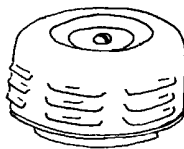

HR-9600-C4 12.50 ea

Exhaust Pipe End Accessories



51A-18259-A	Exhaust deflector, Ford script	20.00	ea
51A-18259-B	Exhaust deflector, V8 script	20.00	ea
51A-18259-P	Exhaust deflector, no script	17.50	ea

Flathead Motor Mounts

Each kit is for one motor mount, includes upper and lower cushions, cups, bolt, nut and washers.

B-6038-K	1932-36 Engine	15.00	ea
78-6039-K	1937-48 Passenger, 1937-51 Pickup also trans mount 1937-41 Pass & 1937-51 Pickup	15.00	ea

Flathead V8 Engine Parts

18-6067-CVR	11/16 Cylinder head nut covers, chrome, 50pc	27.50	set
18-6520-C	9/16" Intake manifold nut covers, chrome, 20pc	12.50	set
48-6750	V8-85 oil dipstick, chrome	15.00	ea

Aluminum "plugmate" spark plug end covers

Polished aluminum. Set of 8

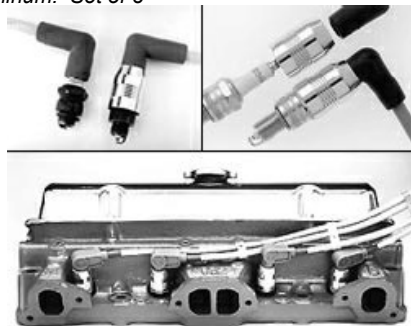

H-12400-CFA	Fits 5/8 late model plug & angled boots	67.50	ea
H-12400-CFAA	Fits 5/8 late model plug in angled plug heads	55.00	ea
H-12400-CFB	Fits 13/16 earlier model plug & angled boots	55.00	ea

Original Type Wiring

1928-39 Light Switches and Parts

Original Ford wiring had the main light switch mounted on the steering box (activated by a rod through the steering wheel and column.

B-3642	Spider spring	0.75	ea
B-3643	Spider	5.00	ea
B-3644	Spider retainer clip	0.50	ea
B-3647	Housing bail	1.50	ea
B-11655	Housing	17.50	ea

1928-31 Wiring Harnesses

Reproductions of the original wiring, for restored cars.

A-11646	Main Light Harness All w/cowl lamps	55.00	ea
A-11647	Main Light Harness All w/o cowl lamps	55.00	ea
A-14401-BHD	Terminal box to coil & dash wire (heavy duty)	10.00	ea
A-14406	Terminal box to generator/starter (in loom)	10.00	ea
A-12275	Spark plug strips, set of 4, (stamped metal)	2.50	set
A-13402	Coil to distributor wires, (3 pieces)	5.00	set
A-14424	Taillight crossover wiring	17.50	ea
A-14300	1928-31 Battery to switch cable	30.00	ea
A-14301	1919-31 Battery ground strap	20.00	ea

1932 Wiring Harnesses

Reproductions of the original wiring, for restored cars.

B-14401-B	Cowl wiring harness, 4 cylinder	40.00	ea
18-14401	Cowl wiring harness, V8's	40.00	ea
18-11646	Main light harness, all w/cowl lamps	70.00	ea
18-11647	Main light harness, all w/o cowl lamps	70.00	ea
A-14426	Cowl light crossover wire	12.50	ea
B-14424	Taillight crossover wiring	20.00	ea

1933-34 Wiring Harnesses

Reproductions of the original wiring, for restored cars.

40-14401	Cowl wiring harness, all V8's	45.00	ea
46-14401-B	Cowl wiring harness, 4 cylinder	45.00	ea
40-11646	Main light harness, all w/cowl lamps	70.00	ea
40-11646-B	Main light harness, all w/o cowl lamps	70.00	ea
A-14426	Cowl light crossover wire	12.50	ea
40-12250	Fuse Block/Ignition Resistor	30.00	ea

1935-36 Wiring Harnesses

Reproductions of the original wiring, for restored cars or pickups.

68-14401	Cowl wiring harness,	70.00	ea
68-11646	Main light harness	75.00	ea
40-12250	Fuse Block/Ignition Resistor	30.00	ea
81A-14405	Taillight extension wiring, only	40.00	ea

1932-36 Battery Cables and Straps

18-14195	1932-34 Battery to switch cable	32.50	ea
18-14431	1932-36 Switch to starter cable	10.00	ea
40-14301-B	1932-36 Battery ground strap	17.50	ea
48-14300	1935-36 Battery to switch cable	30.00	ea

1937-38 Wiring Harnesses

Reproductions of the original wiring, for restored cars or pickups.

78-14401	Cowl wiring harness, 1937 All	70.00	ea
81A-14401-B	Cowl wiring harness, 1938 All	70.00	ea
78-11646	Main light harness, 1937 All	75.00	ea
81A-11646	Main light harness, 1938 All	85.00	ea
40-12250	Fuse Block/Ignition Resistor, 1933-37	30.00	ea
81A-14405	Taillight extension wiring, only	40.00	ea

Original Type Wiring, cont

1939 Wiring Harnesses

Reproductions of the original wiring, for restored cars or pickups.

91A-14401-C	Cowl wiring, Pass w/3 brush generator	85.00	ea
91A-14401-D	Cowl wiring, Pass w/voltage regulator	85.00	ea
91C-14401-A	Cowl wiring, PU & Truck w/3 brush generator	85.00	ea
91C-14401-D	Cowl wiring, PU & Truck w/voltage regulator	85.00	ea
91A-11646	Main light harness, Passenger	85.00	ea
91C-11646	Main light harness, Pickup & Truck	85.00	ea
91A-14405	Taillight extension wiring, only	40.00	ea

1940 Wiring Harnesses

Reproductions of the original wiring, for restored cars or pickups.

01A-14401	Cowl wiring harness, Passenger	95.00	ea
01C-14401	Cowl wiring harness, Pickup & Truck	95.00	ea
01A-11646	Main light harness, Passenger	85.00	ea
01C-11646	Main light harness, 1940-46 PU & Truck	75.00	ea
01A-11652-A	Light switch pigtail, solders to switch	10.00	ea
91A-14405	Taillight extension wiring, only	40.00	ea

1941-47 Pickup & Truck Wiring Harnesses

Reproductions of the original wiring, for restored pickups & Truck

11C-14401	Cowl wiring harness, 1941-42 V8	95.00	ea
51C-14401	Cowl wiring harness, 1944-47 V8	95.00	ea
51C-14401-C	Cowl wiring harness, late 1947 V8	120.00	ea
11C-14401-6	Cowl wiring harness, 1941-44 6 cyl	95.00	ea
01C-11646	Main light harness, 1940-46	75.00	ea
51C-11646	Main light harness, 1947	30.00	ea
21C-14405	Taillight extension wiring (not in 51C-11646 kit)	40.00	ea

1941-48 Passenger Wiring Harnesses

Reproductions of the original wiring, for restored cars.

11A-14401	Cowl wiring harness, 1941	95.00	ea
21A-14401	Cowl wiring, 1942-47, horn behind radiator	95.00	ea
51A-14401	Cowl wiring, 1947-48, horn in front of radiator	120.00	ea
21A-11646	Main light harness, horn behind radiator	85.00	ea
51A-11646	Main light harness, horn in front of radiator	30.00	ea
51A-14405	Taillight extension wiring (not in 51A-11646 kit)	45.00	ea
21A-14302	Coil to distributor wire, 1942	7.50	ea
7RA-14302	Coil to distributor wire, 1947-48	5.00	ea
11A-11652-A	Light switch pigtail, solders to switch	10.00	ea

1937-49 Battery Cables and Straps

A-14300	1937-48 Battery to solenoid cable	30.00	ea
78-14431	1937-48 Solenoid to starter cable	20.00	ea
A-14301	1940-48 Battery ground strap	20.00	ea
78-14301	1937-39 Battery ground strap	17.50	ea
91A-14303	1937-48 Firewall ground strap	15.00	ea

Spark Plug Cable Sets

Reproductions of the original wiring, for restored cars.

18-12259	1932-36 V8 (split ring terminals)	50.00	ea
78-12259	1937-41 V8 (except 60 hp)	50.00	ea
21A-12259	1942-44 V8 (boots included)	50.00	ea
59A-12259	1946-48 V8	50.00	ea

Horn Motor Wiring

46-14436	1933-35 Passenger, 1935-36 Pickup	10.00	ea
68-14436	1936-37 Passenger, 1938-42 Pickup	10.00	ea

Wire Connectors & Frame Clips

B-14487	Wire connectors, 10 pc set	5.00	set
B-14585	Wire to frame clips, 10 pc set	7.50	set

Voltage Reducer, 12v to 6v

Electronic Voltage Converter, maximum 1 amp

SR-10606	1926-55	17.50	ea
----------	---------	-------	----

Hub Caps

Hubcaps, fit original 1928-29 or 1930-31 wheels

A-1130-B	1928-29 (Chrome)	15.00	ea
A-1130-C	1930-31 (Stainless)	15.00	ea

Hubcaps, Fit 1932-35 Ford & Kelsey Hayes Wire Wheels

S-1130-SS	1932 Style, no script	20.00	ea
B-1130-SS	1932 V8 script	20.00	ea
B-1130-BS	1932 "Ford" script	20.00	ea
18-1130-SS	1933 V8 script	20.00	ea
40-1130-BS	1933-34 "Ford" script	20.00	ea
40-1130-SS	1934 V8 script	20.00	ea
40-1130-P	1934 style, plain	20.00	ea
48-1130-SS	1935 V8 script	20.00	ea

Hubcaps, Fit 1936-39 Wide bolt pattern Wheels

68-1130-SS	1936 V8 Script	50.00	ea
------------	----------------	-------	----

Hubcaps For 1940-48 Ford Steel Wheels

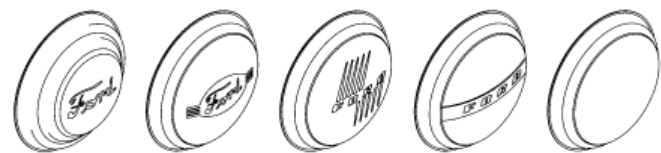

01A-1130-C	1940 "Ford Deluxe"	25.00	ea
01A-1130-A	1940 Deluxe with std style V8	22.50	ea
01A-1130-BM	1940 Deluxe, no script	25.00	ea
01C-1130-BM	1940 Standard, no script	40.00	ea
11A-1130-BM	1941 no script	22.50	ea
21A-1130-BM	1942-48 no script	25.00	ea
01C-1130-SS	1940 "V8", Standard passenger, 1940-41 Pickup	25.00	ea
11A-1130	1941 Passenger "Ford"	25.00	ea
21A-1130	1942 Pass, 1946 Pickup "Ford"	25.00	ea
29A-1130-SS	1942 Mercury	75.00	ea
29A-1130-SM	1942-48 Mercury style, plain	55.00	ea
51A-1130	1946 Passenger "Ford"	25.00	ea
59A-1130-SS	1946 Mercury	75.00	ea
59A-1130-CS	1946-48 Mercury Canada version	75.00	ea
6A-1130-C	1947-48 Pass & 47-56 PU "Ford"	25.00	ea
6M-1130-SS	1947-48 Mercury	75.00	ea

Stainless Steel Beauty Rings

6A-18303-14	For 14" wheels, smooth	27.50	ea
01A-18303-14	for 14" wheels, ribbed	27.50	ea
8A-18303-14	for 14" wheels, convex	40.00	ea
59A-18303-14	for 14" wheels, wave	40.00	ea
6A-18303-15	For 15" wheels, smooth	27.50	ea
8A-18303-15	for 15" wheels, convex	40.00	ea
59A-18303-15	for 15" wheels, wave	40.00	ea
01A-18303-15	For 15" wheels, ribbed	27.50	ea
6A-18303-16	for 16" wheels, smooth	27.50	ea
01A-18303-16	For 16" wheels, ribbed	27.50	ea