

## 1926-31 Roadster and Phaeton Windshield and Top

### 1926-27 Stock Height, Split Glass Windshield

Steel windshield frame includes inside slugs and frame end glass clips

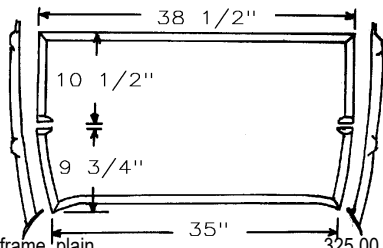

#### Windshield Frame

T-37110-EP	Windshield frame, plain	325.00 ea
T-37110-EC	Windshield frame, chrome	750.00 ea

#### Windshield Posts

T-37135-DP	Stock height, steel, Black	170.00 pr
T-37135-DC	Stock height steel, Chrome	250.00 pr
T-37135-DP4	Chopped	not.avbl

### 1926-37 4" Chopped Windshield Frame

One piece steel frame, chrome plated. Quality chopped posts are not currently available so cut and weld stock height posts.

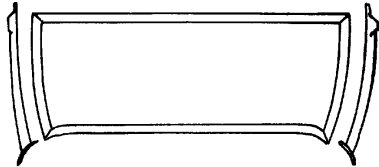

T-37110-EC4	4" Chopped Windshield frame, chrome	750.00 ea
-------------	-------------------------------------	-----------

### 1926-31 Hardware

A-351000	Wingnut, chrome plated	10.00 ea
A-351001-SW	Wingnut washer, stainless	2.50 ea
B-37118-S	Finger pulls, chrome	17.50 pr
A-37154-S	Cone, diecast,	10.00 ea
A-37158-S	Stud & cone nut set	5.00 ea

### Windshield frame rubber

T-37199-ES	1926-27 (post sides and bottom of frame)	20.00 ea
A-37199-AS	1928-29 (post sides & frame bottom)	12.50 ea
A-37199-BS	1930-31 (frame sides and bottom)	17.50 ea

### Glass to Frame Setting Tape

B-37193-A	All years, 20 ft, 1/32" thick	17.50 ea
B-37193-B	All years, 20 ft, 3/64" thick	17.50 ea
B-37193-C	All years, 20 ft, 1/16" thick	25.00 ea
B-37193-D	All years, 20 ft, 5/64" thick	30.00 ea

### Typical 1928-29 Roadster & Phaeton Windshield Components

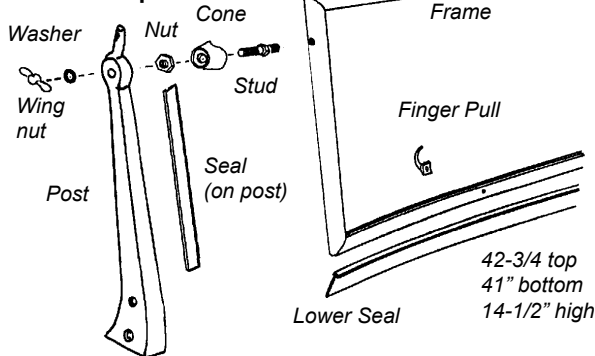

#### Windshield Frames

A-37110-AP	Stock height, plain	300.00 ea
A-37110-AC	Stock height, chrome plated	850.00 ea
A-37110-AC2	Chopped 2", chrome plated	1000.00 ea

#### Windshield Posts

A-37138-A	Stock height, primed steel	275.00 pr
A-37138-AS	Stock height, stainless	275.00 pr
A-37138-ACS	Chopped 2", stainless	325.00 pr
A-37130-M	Post to body screws, set of 4, chrome	5.00 set

### Typical 1930-31 Roadster & Phaeton Windshield Components

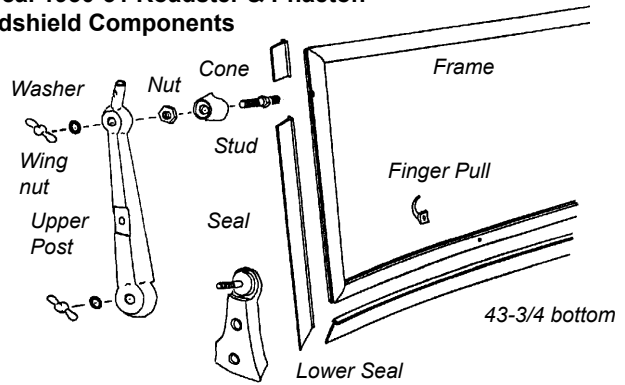

#### Windshield Frames

A-37110-BP	Standard, plain 15 1/4" high at side)	300.00 ea
A-37110-BC	Standard, chrome (15 1/4" high at side)	850.00 ea
A-37110-C	Deluxe, chrome (13 3/4" high at side)	850.00 ea
A-37110-C2	Deluxe, chop 2", chrome	1000.00 ea

#### Upper Windshield Posts:

Polished Stainless Steel.

A-37138-BS	Standard, no windwing or mirror hole	not.avbl
A-37138-CS	Deluxe, LH mirror and windwing holes	325.00 pr
B-37138-CM	150.00 easy modification to lower post.)	pr

#### Lower Windshield Posts

A-37130-S	Lower posts, fabricated steel, with upper studs	210.00 pr
A-37132-LS	Lower post to dash rail lead spacers	12.50 pr
A-37130-M	Lower post to body screws, set of 4, chrome	5.00 set

### Windwing Bracket Sets

Windwings act as side air deflectors. They mount to the back side of windshield posts. Quality 1926-27 windwing brackets are not available so we substitute 1930-35 brackets (chrome, set of 4).

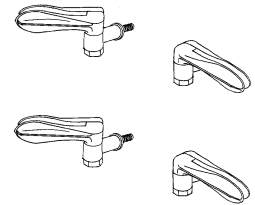

A-18200-B	150.00 set
-----------	------------

### Roadster & Phaeton Windwing Mirrors

B-17700-WWSS	Any Year, Chromed, clamps to windwing	not.avbl
--------------	---------------------------------------	----------

### Windshield Center Mirrors

#### Black Bracket (26-29 style)

A-17681-A	20.00 ea
-----------	----------

#### Chrome Bracket (30-31 Style)

A-17681-B	30.00 ea
-----------	----------

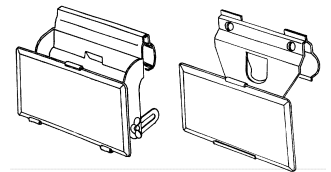

### Windshield Post Mirrors

A-17700-AR	1928-29	50.00 ea
A-17700-P	1930-31	50.00 ea
Mirror head replacement		
B-17741-MH	flat	22.50 ea
B-17741-MHC	convex	20.00 ea

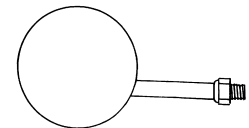

\* Parts with price listed as "not.avbl" are not known to be available at this time, but are listed for reference.

## 1926-31 Roadster and Phaeton Windshield and Top, cont

### 1917-29 and 1930-31 Standard Style

#### Tube style Top Irons and Bows

Top iron kits included tapered tube style irons, wood bows, Windshield post thumbscrews, Top mount nuts (plain), and iron to bow hardware. 1928-31 Roadster PU irons do not fold.

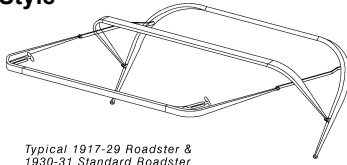

Typical 1917-29 Roadster & 1930-31 Standard Roadster

	Roadster		Touring/4door Phaeton	
1917-22	T-41900-AS	not.avbl	T-37800-AS	not.avbl
1923-25	T-41900-BS	not.avbl	T-37800-BS	not.avbl
1926-27	T-41900-CS	not.avbl	T-37800-CS	not.avbl
1928-29	A-41900-AS	not.avbl	A-37800-AS	not.avbl
1928-29 Roadster PU	A-77600-AS	not.avbl		
1930-31	A-41900-BS	not.avbl	A-37800-BS	not.avbl
1930-31 Roadster PU	A-77600-BS	not.avbl		

### 1930-31 Deluxe Roadster

#### Top Irons and Bows

Deluxe style irons use flat bar construction and fold like original.

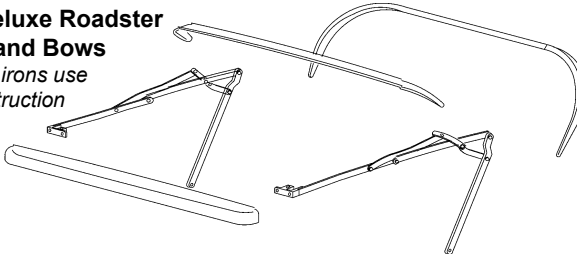

A-42030-PS	Top irons, pln w/stainless arm	1500.00	set
A-42030-PS2	Top irons, chop 2", pln w/stnl arm	1500.00	set
A-42030-CS	Top irons, stainless	1750.00	set
A-42030-CS2	Top irons, chop 2" stainless	1750.00	set
A-42055-S	Top wood header & 2 bows	550.00	set
A-180600-S	Rear bow lower chrome mount T bolt	17.50	pr

### 1930-31 Deluxe (2-Door) Phaeton Top Irons and Bows

Deluxe style irons use a flat bar construction and fold like original.

A-38700-PS	Top irons, pln w/stainless arm	not.avbl
A-38700-PS2	Top irons, chop 2", pln w/stnl arm	not.avbl
A-38700-CS	Top irons, stainless	not.avbl
A-38700-CS2	Top irons, chop 2" stainless	not.avbl
A-37455-S	Top wood header & 3 bows	800.00

### 1930-31 Top iron corner brackets

Cast stainless. Fit deluxe roadster and deluxe (2 door) phaeton

WA-42030-HBL	LH	125.00	ea
WA-42030-HBR	RH	125.00	ea

### Top Iron to Windshield Post Thumbscrew

Clamps top irons to windshield posts.

Fine thread, 1917-29, 1930-31 Standard			
A-37472-F	10.00	ea	
Coarse thread, 1930-31 Deluxe			
B-37472	12.50	ea	

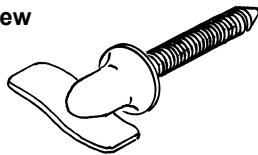

### Top to Body Mount Hardwarer

<b>Nut and lockwasher</b>			
B-37708-B	Nut, stainless clad	7.50	ea
B-52550	Folding lockwasher	2.50	ea

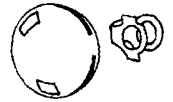

### Top mount Stud: 1926-27 Roadster, 1926-31 Touring and Phaeton

A-36636-A	1926-27 Roadster & Touring	25.00	ea
	1928-29 Phaeton		
A-36636-B	1930-31 Fordor Phaeton	25.00	ea

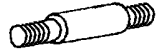

### Top Mount on Quarter Panel 1928-31 Roadster and Roadster PU

B-42027	Bracket, plain	25.00	ea
B-42027-SS	Bracket, polished stainless	50.00	ea
B-42034-P	Bolt, Plain	0.50	ea
B-42034-S	Bolt, Stainless clad	0.75	ea

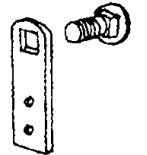

### Top Rest Saddles

#### 1926-27 Roadster & Touring 1928-31 Standard Phaeton

T-3314-BS	Saddles, cast Iron	17.50	ea
T-3858-BS	Studs, 1926-27 Roadster and Touring	12.50	ea
A-37329-A	Studs, 1928-29 Phaeton	25.00	ea
A-37329-B	Studs, 1930-31 Fordor Phaeton	25.00	ea
T-3629-S	Strap and Pad Set, leather	30.00	set

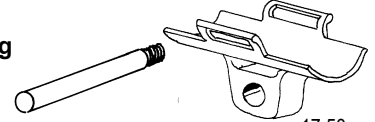

### Top Rest Saddles

#### 1930-31 Delxue (2-door) Phaeton

Deluxe had both an early (short) and late (tall) version top saddle

A-191934-B	Saddles, tall version, cast stainless	150.00	ea
A-191928-PR	Studs, tall version	32.50	pr
B-37330-SET	Set screw, square head, stainless	2.00	ea



### Roadster Top Tie Down Brackets

Usually called rumble seat grab handles, these are really for resting the top irons on when the top is folded, and to tie it down.

A-41500-SS	45.00	pr
------------	-------	----

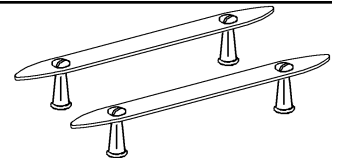

### Side Curtain Rods

Exact reproduction, with flattened top and tapered bottom end.

A-41970-AR	1928-29 Roadster	60.00	pr
A-41970-C	1928-29 Phaeton and Roadster Pickup	70.00	pr
A-41970-B	1930-31 Std Roadster & Std Phaeton	60.00	pr
A-41970-D	1930-31 Deluxe Phaeton	85.00	pr
A-41970	1930-31 Deluxe Roadster	70.00	pr

### Side Curtain Parts

A-41970-B	Snap sockets, 1928-37 (in body)	60.00	pr
A-37103	Studs, 1928-36 (for windshield), set	45.00	set
A-37103	Studs, 1928-36 (for windshield)	45.00	set
A-37102	Studs, 1930-31 (for tack strip)	65.00	set

### Back Window Frames

(glass not included)

#### 1928-31 Roadster, Phaeton, Cabriolet (16 5/8" x 7" od)

A-37639-PL	Stainless outer/tan inner	not.avbl
A-37639-SS	Stainless outer and inner	not.avbl

#### Aluminum Mailslot (20" x 4 1/2" od)

H-37639-C	Polished Aluminum	not.avbl
-----------	-------------------	----------

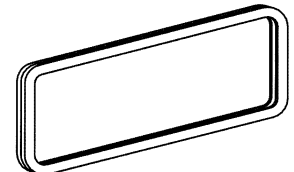

\* Parts with price listed as "not.avbl" are not known to be available at this time, but are listed for reference.